

# WHEEL ALIGNMENT SYSTEMS

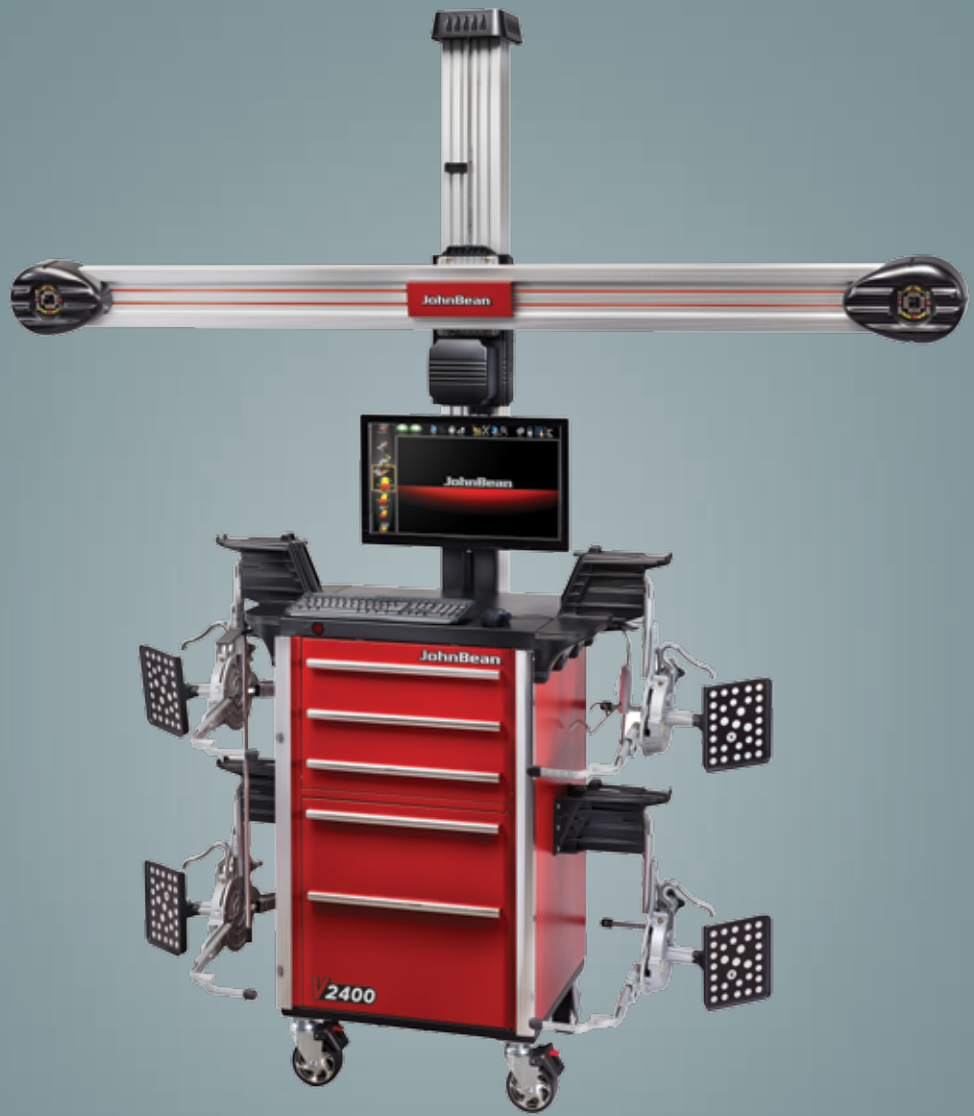

## PINPOINT ALIGNMENT PROBLEMS FASTER AND EASIER THAN EVER BEFORE.

Target more alignment revenue and zero comebacks.

INTRODUCING THE **V2400** WHEEL ALIGNMENT  
SYSTEM

**JohnBean**

# THE V2400 WHEEL ALIGNMENT SYSTEM. PRECISELY WHAT YOU NEED FOR THE MOST PRECISE READINGS.

Our new, redesigned V2400 wheel alignment system features improved camera and target technology and the smallest and lightest XD target system we've ever offered. It also provides highly accurate and repeatable measurements, to help you get the job done quicker and eliminate comebacks.

## CUTTING EDGE HARDWARE PROVIDES ACCURATE, ADVANCED DIMENSIONING.

The V2400's high resolution cameras produce accurate, live alignment readings and diagnostic data. It also utilizes passive front and rear XD targets that are highly durable, with no electronics to damage. Cross-diagonal measurements identify frame damage, while Rolling Radius detects mismatched tire sizes. And it provides all the benefits of our AC400 Touchless Alignment Wheel Clamp. But maybe best of all, the V2400 is so lightweight and simple to operate, you don't have to be a highly-skilled alignment tech to master it.

## FEATURES

- John Bean AC400 Touchless Alignment Wheel Clamping System
- VODI™ Vehicle Orientation Directional Indicator Guides Users Through the Measurement Process
- Measures Camber, Caster, Toe, Rolling Radius, Cross-Diagonal, Wheelbase and Track Width
- EZ-Toe Lets You Turn the Front Wheels and Access Difficult Adjustment Points When Setting Toe

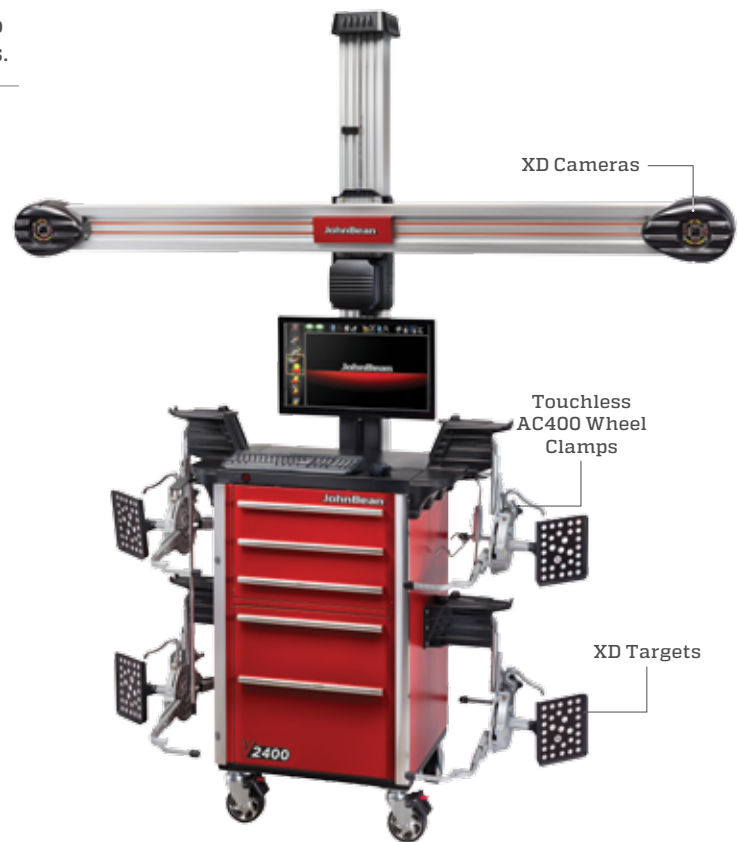

## AVAILABLE MODELS

- V2400 with AC400 Wheel Clamps (EEWA546R)
- V2400 with AC400 Wheel Clamps & ETHOS+ (EEWA546RE)
- V2400 with AC200 Wheel Clamps (EEWA546S)
- V2400 with AC200 Wheel Clamps & ETHOS+ (EEWA546SE)

## STANDARD ACCESSORIES

- Wheel Clamps and Targets
- Steering Wheel Holder
- Brake Pedal Depressor
- Color Inkjet Printer
- (2) Wheel Chocks

## SPECIFICATIONS

- Tire Diameter: 19"-39" (48.3cm-99.1cm)
- Track Width: 48"-96" (112cm-244cm)
- Wheel base: 79"-180" (201cm-457cm)
- Shipping weight: 300 lbs (136kg)
- Power requirements: 100-240V 1 Ph 50/60HZ UL201, C22.2, CE Approved

For more information regarding the **V2400** call **800.362.4618 (US)** or **800.362.4608 (Canada)**  
[www.johnbean.com](http://www.johnbean.com) / [www.johnbean.ca](http://www.johnbean.ca)

# JohnBean

John Bean is committed to product innovation and improvement. Therefore, specifications listed in this sell sheet may change without notice. ©2015 Snap-on Incorporated. John Bean is a trademark, registered in the United States and other countries, of Snap-on Incorporated. All rights reserved. All other marks are marks of their respective holders.

10/15 SS153488B