

SPECIFICATIONS

BFH 1000	
EEWB519B	
Max. Wheel & Tire Assembly Weight	154 lbs.
Max. Wheel & Tire Assembly Diameter	44"
Max. Wheel & Tire Assembly Width	21"
Max. Wheel Diameter	30"
Shaft Diameter	40 mm
Length of Shaft	7.5"
Data Entry (Distance, Diameter, Width)	Automatic, Non-Touch
Power Clamp Configuration	Yes
Quick-Nut Configuration	No
Weight Storage Pockets	23
Display	Elevated Flat Screen Monitor
Measuring Speed	200 RPM
Balance Accuracy	0.05 oz.
Scanner Accuracy	0.0039"
Dimensions (DxWxH)	64" x 64" x 64"
Shipping Weight	550 lbs.
Power Requirements*	230V, 1Ph, 60Hz

* Other Power Configurations Available



SPACE REQUIREMENTS

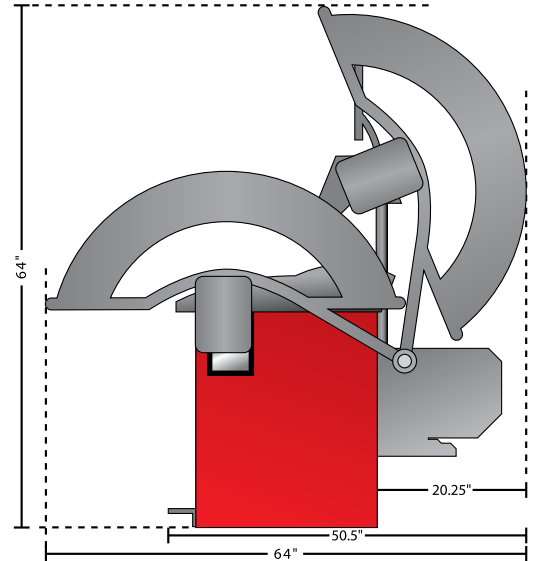
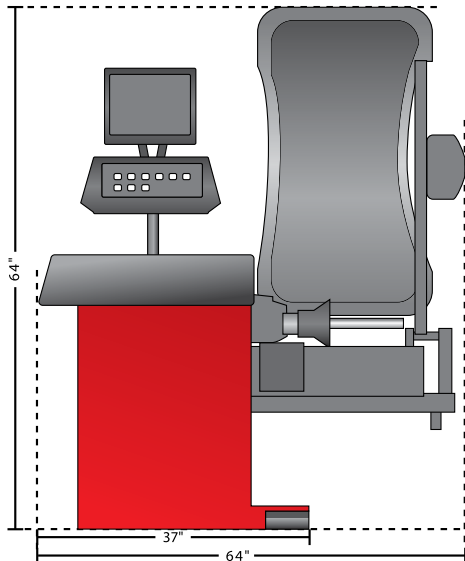

Snap-on Equipment / 309 Exchange Avenue / Conway, Arkansas 72032 U.S.A.
 Fax: 501-450-2085 / Toll Free: 1-800-362-4618 / International: 501-505-2739
www.SnaponEquipment.com

John Bean Canada / 6500 Millcreek Drive / Mississauga, Ontario L5N 2W6
 Customer Service: 1-800-362-4608 / Fax: 905-826-7800
www.johnbean.ca

