



## COMPUTER WHEEL BALANCER



**BFH 800C**  
**EEWB526C**

Operator's Manual

ZEEWB526C Rev C

April 02, 2010

## **SAFETY INFORMATION**

**For your safety, read this manual thoroughly  
before operating the BFH 800 Wheel Balancers**

The JBC BFH 800 Wheel Balancers are intended for use by properly trained automotive technicians. The safety messages presented in this section and throughout the manual are reminders to the operator to exercise extreme caution when servicing tires with these products.

There are many variations in procedures, techniques, tools, and parts for balancing tires, as well as the skill of the individual doing the work. Because of the vast number of wheel and tire applications and potential uses of the product, the manufacturer cannot possibly anticipate or provide advice or safety messages to cover every situation. It is the automotive technician's responsibility to be knowledgeable of the wheels and tires being serviced. It is essential to use proper service methods in an appropriate and acceptable manner that does not endanger your safety the safety of others in the work area or the equipment or vehicle being serviced.

It is assumed that, prior to using the BFH 800 Wheel Balancer, the operator has a thorough understanding of the wheels and tires being serviced. In addition, it is assumed he has a thorough knowledge of the operation and safety features of the rack, lift, or floor jack being utilized, and has the proper hand and power tools necessary to service the vehicle in a safe manner.

Before using the BFH 800 Wheel Balancer, always refer to and follow the safety messages and service procedures provided by the manufacturers of the equipment being used and the vehicle being serviced.



**IMPORTANT !! SAVE THESE INSTRUCTIONS -- DO NOT DISCARD !!**

# IMPORTANT SAFETY INSTRUCTIONS

When using this equipment, basic safety precautions should always be followed, including the following:

1. **READ ALL INSTRUCTIONS.**
2. **Do not operate equipment with a damaged power cord or if the equipment has been damaged - until it has been examined by a qualified authorized service technician.**
3. **If an extension cord is used, a cord with a current rating equal to or more than that of the machine should be used. Cords rated for less current than the equipment may overheat. Care should be taken to arrange the cord so that it will not be tripped over or pulled.**
4. **Always unplug equipment from electrical outlet when not in use. Never use the cord to pull the plug from the outlet. Grasp plug and pull to disconnect.**
5. **To reduce the risk of fire, do not operate equipment in the vicinity of open containers of flammable liquids (gasoline).**
6. **Keep hair, loose fitting clothing, fingers and all parts of the body away from moving parts.**
7. **Adequate ventilation should be provided when working on operating internal combustion engines.**
8. **To reduce the risk of electric shock, do not use on wet surfaces or expose to rain.**
9. **Do not hammer on or hit any part of the control panel with weight pliers.**
10. **Do not allow unauthorized personnel to operate the equipment.**
11. **Do not disable the hood safety interlock system or bypass the intended operation.**
12. **Use only as described in this manual. Use only manufacturer's recommended attachments.**
13. **Always make sure the power clamp is secure before spinning the shaft.**
14. **ALWAYS WEAR SAFETY GLASSES. Everyday eyeglasses only have impact resistant lenses, they are NOT safety glasses.**
15. **Balancer is for indoor use only.**
16. **This equipment uses class II lasers. Do not look into or allow bystanders to look into the laser source.**

**SAVE THESE INSTRUCTIONS**

**CAUTION!** This product uses **LASER RADIATION** for measurements. **DO NOT STARE INTO BEAM.**

Refer to these laser safety statements whenever this sign is displayed.



Peak power 1.0 mW.  
Pulse duration 5 m sec.  
Emitted wavelength 650nm.

Class II laser product. Caution - the use of optical instruments with this product will increase risk of eye hazard.



**WARNING!!! DO NOT STARE INTO LASER BEAM! EYE INJURY MAY OCCUR WITH PROLONGED EYE CONTACT WITH LASER. AVOID EYE CONTACT WITH THE LASER SCANNERS**

**WARNING!!! IN THE EVENT OF MACHINE MALFUNCTION, DO NOT LOOK INTO THE LASER AREA. PROLONGED EXPOSURE TO THE LASER MAY CAUSE EYE INJURY.**



PERFORM REGULAR CLEANING OF THE LASER SCANNER GLASS TO ENSURE OPTIMUM OPERATION.

**DO NOT KNOCK OR TAMPER WITH THE LASER SCANNERS**

**ALWAYS OPERATE THE WHEEL BALANCER WITHIN THE RANGES STATED IN THE LABEL SHOWN BELOW.**

**CAUTION!** - Use of Controls or adjustments or performance of procedures other than those specified herein may result in hazardous radiation exposure.



**WARNING!!!SEVERE PERSONAL INJURY WILL OCCUR IF FINGERS OR HAND IS PINCHED BETWEEN THE CLAMP NUT, WHEEL OR FLANGE**

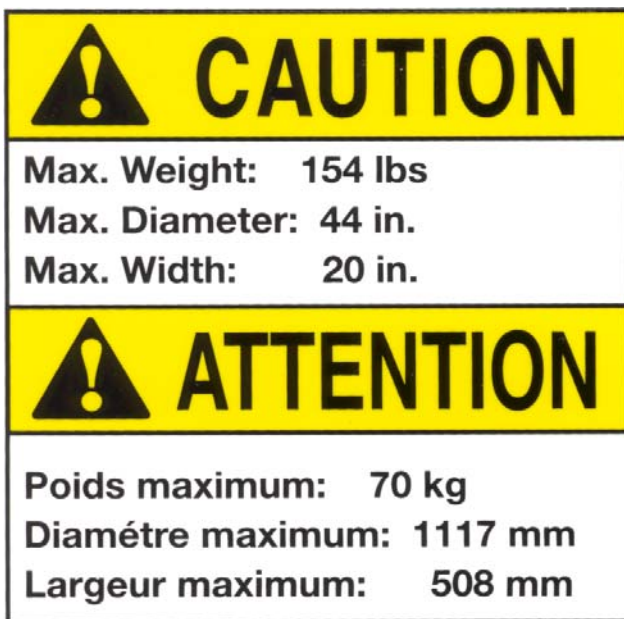

# Table of Contents

<b>SAFETY INFORMATION</b> .....	<b>I-II</b>
1.0 INTRODUCTION .....	1
1.1 SAFETY NOTICE .....	1
1.2 BALANCER APPLICATION .....	2
1.3 BFH 800 SPECIFICATIONS .....	2
1.4 FEATURES .....	2
1.7 DIMENSIONS OF THE MACHINE .....	4
1.8 INSTALLATION AREA REQUIREMENTS .....	4
1.9 INSTALLATION PRECAUTIONS .....	5
2.1 INSTALLATION OF THE HOOD GUARD .....	5
2.2 MONITOR INSTALLATION .....	5
2.3 ELECTRIC INSTALLATION .....	6
2.4 SETUP .....	7
3.0 PHYSICAL LAYOUT .....	9
3.2 MENU KEYS .....	10
3.2.2 MAIN MENU FUNCTIONS .....	11
3.2.3 BALANCING .....	11
3.2.8 FUNCTION (SETUP) .....	13
4.0 HELP INFORMATION .....	14
5.0 POWER CLAMP .....	15
6.0 OPERATION OF THE BALANCER .....	16
6.1 CHECK LIST - INSPECTION .....	16
6.2 BALANCE SCREEN DESCRIPTION .....	17
6.2.1 WHEEL MOUNTING .....	18
6.2.2 STANDARD WHEELS (BACK CONE MOUNT) .....	18
6.2.3 CENTERING LIGHT-TRUCK WHEELS .....	18
6.3 SCAN MODE SELECTION .....	19
6.3.1 DATA FREEZE MODE .....	19
6.4 SPINNING THE WHEEL .....	19
6.5 SELECTING THE WEIGHT PLACEMENT .....	20
6.6 CORRECTION OF THE IMBALANCE .....	20
PROCEDURE WHEN SCANNER FAILS TO ACQUIRE A VALID PROFILE .....	21
6.7 VERIFICATION OF THE RESULTS .....	21
6.8 VIBRATION PROBLEMS .....	22
7.0 SPOKE BALANCING MODE .....	22
8.0 OPTIMISATION PROCEDURES .....	23
9.0 WEIGHT MANAGEMENT .....	28
9.1 OPTIONAL WEIGHT MISER .....	29
10.0 USER CALIBRATION .....	31
11.0 EXPLANATION OF PROGRAM CODES .....	32
12.0 MAINTENANCE .....	34
13.0 TROUBLE SHOOTING .....	34



## 1.0 INTRODUCTION

Congratulations on purchasing the **BFH 800** Computer Wheel Balancer. This wheel balancer is designed for ease of operation, accuracy, reliability and speed. With proper maintenance and care your wheel balancer will provide many years of trouble-free operation.

### BFH 800 Computer Wheel Balancer - Precautions To Observe



Your BFH 800 Balancer utilizes the latest in electronics and instrumentation technology, incorporating two separate scanning lasers along with an embedded computer (PC). Following the precautions listed below will help to ensure continuous and satisfactory operation of your unit.

- 1) Install the balancer on a dedicated power line in order to avoid electrical noise and power line fluctuations. Avoid power cord length greater than 15 feet.
- 2) The BFH 800 Wheel Balancer utilizes a red scanning laser which actually create an image of the wheel being serviced. Install the balancer away from direct sunlight so that the laser can be detected by the scanner. Avoid placing high intensity lamps and infrared heaters near the BFH balancer.
- 3) Profile and balance only those wheels which fit within the specifications of the BFH Balancer:  
Rim width = 3 - 20 inches  
Rim diameter = 8 - 30 inches  
Max tire diameter = 44 inches  
Minimum distance required from cabinet to rim edge = 56 mm (2.20 inches) for wheel sizes 13-18 inches in diameter.  
Minimum distance required from cabinet to rim edge = 81 mm (3.19 inches) for wheel sizes 19-24 inches in diameter.
- 4) The BFH balancer is designed to properly scan the profile of existing rims. Extreme geometric combinations of rim diameter and flange offset can inhibit the proper viewing of the rim profile. These exceptional rims can be properly balanced by manually entering the distance, diameter, and width of the rim.
- 5) The wheel guard of the BFH 800 Wheel Balancer also serves as the housing for sonic transducers. Since the transducer must remain stationary once the spin cycle begins, do not lean on or otherwise disturb the wheel guard until the spin cycle has been completed.

Instructions on use, operational requirements and routine maintenance of the machine are covered in this manual.

This unit uses an open source Linux operating system for its user interface. This open source code is available for the cost of shipping and handling to owners of the BFH 800 Wheel Balancer. Request must be made to the attention of balancer product management at the Conway, AR address listed on the back of this manual. Please include the owners name, address and unit serial number with all requests.

**STORE THIS MANUAL IN A SAFE PLACE FOR FUTURE REFERENCE.  
READ THIS MANUAL THOROUGHLY BEFORE USING THE MACHINE.**

### 1.1 SAFETY NOTICE

This manual is a part of the balancer product. Read carefully all warnings and instructions of this manual since they provide important information concerning safety and maintenance.

---

## 1.2 BALANCER APPLICATION

The John Bean BFH 800 Computer Wheel Balancer is intended to be used as a device to correct imbalance and correct car, and light truck wheel vibration problems within the following range:

Maximum tire diameter	: 44" (1117mm)	Maximum wheel diameter:	30" (762mm)
Maximum wheel width	: 20" (381mm)	Maximum wheel weight :	154 lbs (70 kg)

This device is to be only used in the application for which it is specifically designed. Any other use shall be considered as improper and thus not reasonable.

The manufacturer shall not be considered liable for possible damages caused by improper, wrong or non reasonable use.

## 1.3 BFH 800 SPECIFICATIONS

Weight Imbalance Accuracy	.05 oz / 1 gram
Weight Placement Resolution	± .7 degrees
Weight Imbalance Resolution:	
Roundoff Mode	.25 oz / 5 grams
Non-Roundoff Mode	.05 oz / 1 gram
Max. Shaft Weight Capacity	154 lbs / 70 kg
Max. Tire Diameter	44" / 1117 mm
Rim Width Capacity	3.0"-20" / 76 mm - 508 mm
Max. Tire Width	21" / 530 mm
Rim Diameter Capacity	8"-30"/203mm-762mm
Balancing Cycle Time.	20 seconds or less
Shaft Speed at calculation	200 RPM
Electrical	230vac, 1ph, 50-60Hz, 3.2A
Required Work Area	64" x 64" (1626 x1626 mm)
Shipping Weight, complete	645 lbs/293kg
Shipping Dimensions	72"L X 73"W X 63"D (1829x1854x1600mm)
Machine Dimensions	64"h 64"w 64"d (1626x1626x1626mm)
Actual Weight with Accessories	550 lbs
Operating Temperature Range	32-122F / 0-50C

## 1.4 FEATURES

- Self test check with every power up cycle.
- Pre-programmed Error Codes indicate procedural errors or safety concerns.
- Fully Automatic All-ParameterData Entry.
- Fully Automatic Rim Profiling.
- Optional Weight Miser™ and Weight Wizard™ software
- Fully Automatic Spoke/Split Weight Function for Hidden Weight Placement.
- Hands-Free Power Clamping for Precise Wheel Placement.
- Captured back spring eliminates having to handle the backing spring.
- Automatic recalculation if weight positions are changed. No need for re-spinning the wheel.
- Common 40 mm diameter mounting shaft.
- Easy-to-Read LCD Data Display Monitor.
- Dynamic and single weight Static capability.
- Stop-at-Top features simplifies weight imbalance location
- Automatic Weight Type Selection Based on Rim Profile, Indicated by Color Coded Icons
- Built-in spin counter for monitoring balancer productivity
- Service code access to all Balancer electronic functions for fast, easy diagnosis.
- Operator selectable roundoff mode.

### 1.5 STANDARD ACCESSORIES

Standard accessories ( Figures 1, 2, and 3,) included with the BFH 800 are:

- 1 EAM0005D40A Weight - Calibration
- 2 EAC0060G02A Flange - Cover, Hook
- 3 EAM0006G01A Pin - Accessory
- 4 58839 Weight Pliers
- 5 EAA0247G21A Caliper - Rim Width
- 6 EAA0283D53A Power Clamp Nut

**Power Clamp Nut Accessories:**

- A EAC0058D15A Soft Protective Ring
- B EAC0058D07A Cup - Large Pressure
- D EAM0005D54A Plastic Sleeve
- E EAC0058D08A Small Pressure Disk

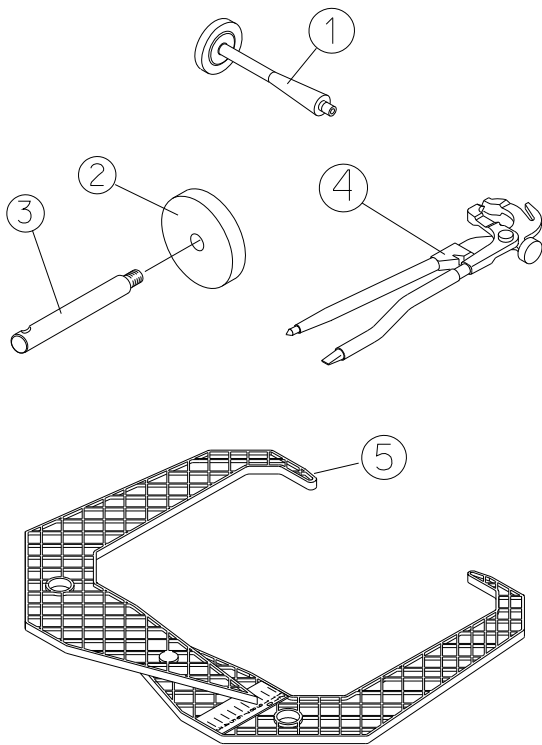

Figure 1- Standard Accessories

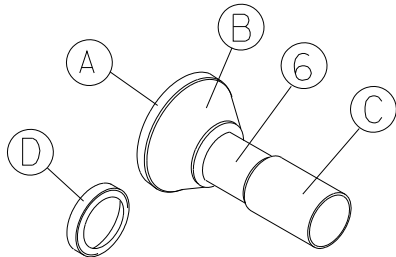
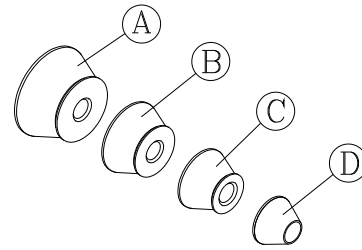

Figure 2 - Power Clamp Nut Accessories

### 1.6 OPTIONAL ACCESSORIES



4 PC Cone Kit, p/n EAK0221J60A, contains:

- A EAM0003J08A Cone, 85-132 mm / 3.3"-5.2"
- B EAM0003J07A Cone, 71-99 mm / 2.8"-3.9"
- C EAM0003J06A Cone, 56-84 mm / 2.2"-3.3"
- D EAM0003J05A Cone, 43-63 mm / 1.7" - 2.5"

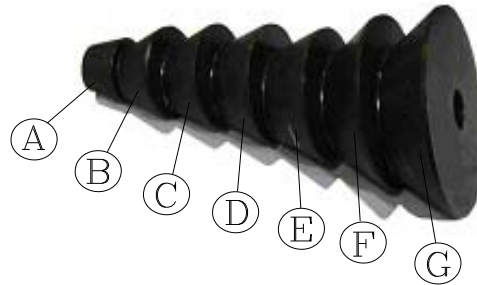

7PC Cone Kit, p/n EAK0221J31A, contains:

- A EAM0003J64 Cone 1.70" TO 2.23"
- B EAM0003J65 Cone 2.03" TO 3.17"
- C EAM0003J66 Cone 2.38" TO 3.51"
- D EAM0003J67 Cone 2.74" TO 3.87"
- E EAM0003J68 Cone 3.08" TO 4.21"
- F EAM0003J69 Cone 3.42" TO 5.40"
- G EAM0003J70 Cone 4.21" TO 6.30"

**NOT SHOWN:**

Unilug adapter kit - pn 110614  
Truck cone kit - pn 110612  
Motorcycle adaptor kit - pn - EAA0260D80A  
and the below pictured options:

Figure 4 - Optional Accessories



Stick-on Weight Removal Tool  
EEHT300A



Flange Plates - Kit of 4  
EAK0221J22A



Flange Plate Cart  
EAS2081J30A

**PRE-INSTALLATION CONSIDERATIONS**

**1.7 DIMENSIONS OF THE MACHINE**

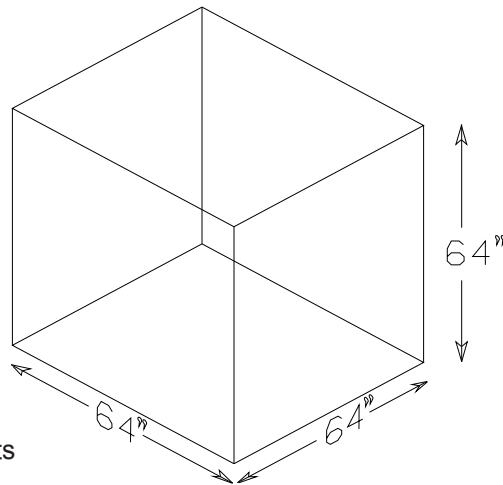

Figure 5 - Footprint Requirements

**1.8 INSTALLATION AREA REQUIREMENTS**

Make sure that from the operating position the user can see all of the machine and the surrounding area.

The operator should prevent non authorized persons and/or objects from entering the area which may create potential hazards.

The machine should be installed on a stable level floor. Do not install the machine on a uneven floor

If the balancer is to be installed on a raised floor, the floor must have a capacity of at least 110lbs per sq f. (5000 N/m<sup>2</sup> - 500 kg/m<sup>2</sup>).

It is not required to secure the machine to the floor but is recommended.

Install the machine in a dry covered area.

The installation of the machine requires a working area of at least 64" x 64" (1626 x1626 mm) See Figure 5

## 1.9 INSTALLATION PRECAUTIONS

### **CAUTION! CAREFULLY REMOVE THE BALANCER FROM THE PALLET.**

Remove the hardware that secures the machine to the pallet and slide the balancer onto the floor where it is to be installed.

**THE UNIT IS HEAVY AND THE WEIGHT IS NOT EVENLY DISTRIBUTED.**

**DO NOT LIFT THE BALANCER BY THE SHAFT OR WHEEL GUARD FRAME.**

**DROPPING THE UNIT MAY CAUSE PERSONAL INJURY OR EQUIPMENT DAMAGE.**

## 2.0 INSTALL ACCESSORY PINS

A. Install the accessory pins (Figure 6). Tighten firmly.

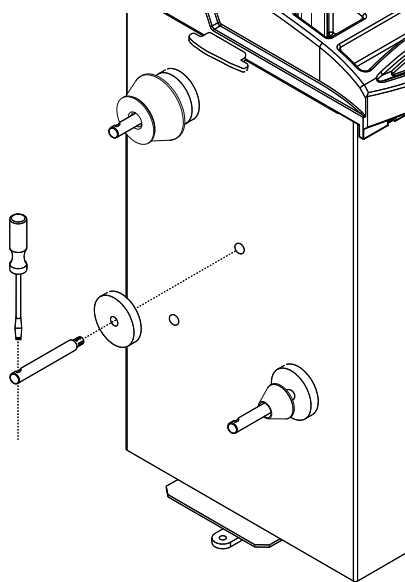

Figure 6

B. Place accessories onto the accessory pins.

### **2.1 INSTALLATION OF THE HOOD GUARD**

2.1.1 Place the hood guard frame onto the pivot tube. Line up the holes in both frame and pivot, insert bolt. Secure using the supplied nut in the down position.

2.1.2 Connect the sonic transducer cable to short cable on the rear of the cabinet.

2.1.3 Pivot the frame up and down carefully and make sure the guard moves freely, the cable does not bind and the guard does not fall by itself.

### **2.2 MONITOR INSTALLATION**

Beginning early December 2008 Wheel Balancers utilizing a flat panel monitor will be provided with a universal VESA video adapter bracket for mounting of the flat panel monitors.

Mounting configuration may vary depending upon the supplied monitor model. See the description below for instructions

#### **HOW TO ASSEMBLE**

1. Remove the monitor factory installed base assembly so the bare monitor remains, see Figure 7. Some flat panel monitors may have a plastic cover over the factory base. To remove the plastic base cover insert a flat blade screwdriver under one corner of the base cover and pry gently until the cover releases.



Figure 7

2. Remove the base by removing the four phillips screws. Secure the screws if desired. See Figure 8.



Figure 8

3. Locate the VESA monitor bracket and orientate as shown in Figure 9.
4. Using the supplied hardware, Loosely secure the VESA bracket to the monitor. Once all four screws are inserted tighten firmly being sure to avoid overtightening.

**NOTE:** Some monitors may have 75mm x 75mm configurations while others may have 100mm x 100mm configurations. Select what is appropriate for the supplied monitor.

5. Connect the Video and power cables to the monitor
6. Secure the monitor-bracket assembly to the tower support using the lower pivot screw hole.

**NOTE:** Some monitors may use one of the remaining pivot holes in the future. Use your best judgment when selecting the proper pivot hole.

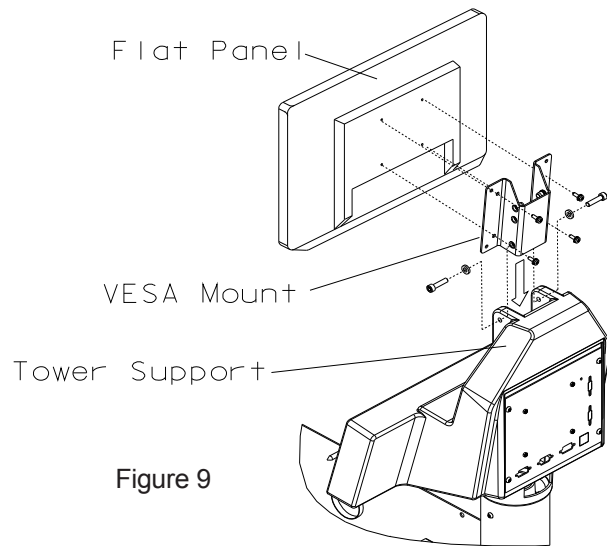

Figure 9

## 2.3 ELECTRIC INSTALLATION

**ANY ELECTRICAL WIRING MUST BE PERFORMED BY LICENSED PERSONNEL.**

**ALL SERVICE MUST BE PERFORMED BY AN AUTHORIZED SERVICE TECHNICIAN.**

Check on the plate of the machine that the electrical specifications of the power source are the same as the machine. The machine uses 230VAC (+/- 15%), 50-60Hz, 1Ph, 3.2Ampere.

**NOTE: ANY ELECTRICAL OUTLET INSTALLATION MUST BE VERIFIED BY A LICENSED ELECTRICIAN BEFORE CONNECTING THE BALANCER.**

**NOTE: THIS MACHINE PERFORMS A SELF-TEST ROUTINE ON START-UP. THERE WILL BE A DELAY OF SEVERAL MOMENTS BEFORE UNIT IS READY FOR OPERATION. ANY PROBLEMS DETECTED AT START-UP WILL RESULT IN THE DISPLAY OF AN ERROR CODE. PROBLEMS DETECTED DURING OPERATION ARE SAVED TO A LOG FILE WHICH CAN BE RETRIEVED FOR DIAGNOSIS BY A TECHNICIAN.**

## 2.4 SETUP

Every shop has different procedural requirements meaning each machine should be customized to the unique services performed at that location. Most attributes are set from the Main Function menu.

### 2.4.1 Customizing the System

- A. Select the "Function" key (F1) from the "Welcome" menu. The Main Function setup screen appears as in Figure 10 as show on next page.
- B. Press and hold the "F6" button and rotate the shaft to scroll up or down to the desired line item.
- C. Press and hold the "F5" button and rotate the wheel to change selected topic to desired value or function.
- D. When the desired features have been selected, save selections to permanent memory by selecting line item "3". Hold the F5 button while rotating the shaft, enter a value of "1", release **Save to Permanent Memory**.
- E. Select the "ESC" button on the keyboard to return to the main screen.

Balancer operating mode (0 = manual, 1 = profiling)	1
Setting factory default modes of operation	0
Saving modes of operation in permanent memory	0
Language selection	English – uk
Volume of the audible signals	50
Resolution of the unbalance amount readings	Normal
Suppression of minor unbalance readings	On
Setting threshold value for unbalance suppression in oz	0.25 oz
Measurement unit of the unbalance amount readings	Ounces
Number of revolutions	10
Starting a measuring run by closing the wheel guard	On
Automatic braking when wheel guard is raised	On
Releasing of the power clamping device disabled	Off
Actuation direction of pedal for clamping/releasing	Raise
Date: Day	11.--.--
Date: Month	--.04.--
Date: Year	--.--.06
Time: Hour	12:--
Time: Minute	--:30
Counter ( total spins / spins with ok )	1555 2
Counter ( optimisation runs / clamping cycles )	5 15
Counter ( since last calibration / service )	126 11
Screensaver timeout (0 = disabled)	0
Position brake and indexing	2
Networkmode (0=no network, 1=ASA)	0
Machine name in network	WB01
Printing	Off
Paper size	Letter
Printer model	HP Deskjet D2430
Print on unclamping	Off
Advanced spoke detection	Off
Weight usage tracking	On
Weight Placement Default Selection	Auto
Rim cleaning position brake control	Off
Allow unclamping of wheel only if imbalance = 0 and OK	Off
Enable WeightMiser	On
Setting static threshold value for WeightMiser in oz	0.20 oz
Setting dynamic threshold value for WeightMiser in oz	0.35 oz
WeightMiser clip weight to money conversion	1 / lb
WeightMiser stick weight to money conversion	1 / lb

Figure 10

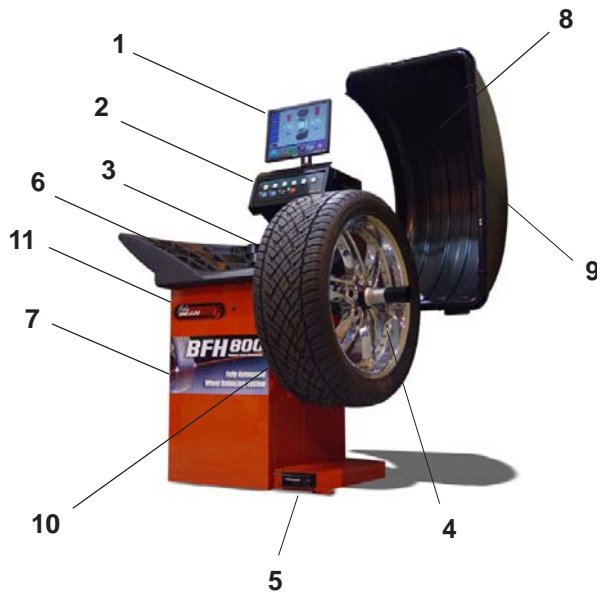

Figure 11

### 3.0 PHYSICAL LAYOUT

Refer to Figure 11. - Functional description of the unit:

1. The screen
2. Input panel
3. Gauge arm
4. Stub shaft with power clamp nut
5. Brake pedal
6. Weight compartments
7. Storage areas for cones or clamping devices
8. Tilting frame and hood guard
9. Sonic Transducer
10. Inner scanner



### 3.1 The Display Screen

See Figure 12, Screen with display fields

- 1-5 Information fields
  - 6 Menu fields and Function descriptors.
  - 7 Display field of screen
- The screen reads out inputs, helpful information, all measured data and error codes.

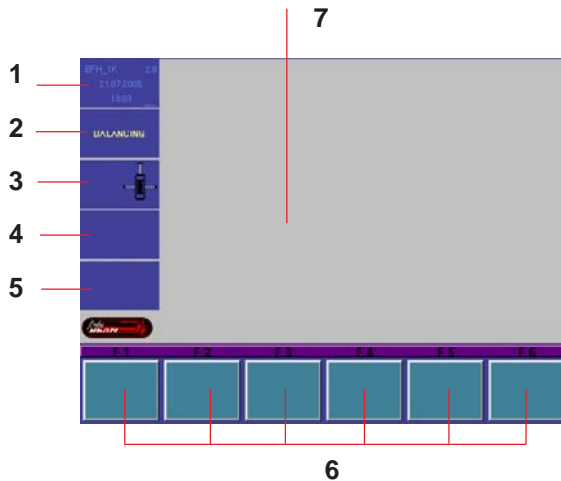

Figure 12

#### Detailed description of display fields

The screen is subdivided into various display fields, each of which is associated with a certain type of information.

#### Information fields

- 1 Number of the installed program version  
Machine name  
Date and time
- 2 Selected Menu name
- 3 Selected profiling mode
- 4 Electrical compensation
- 5 Error codes

#### 6 Menu fields

Icons illustrating special features or functions are viewed in the six menu fields. Under every menu field is the associated menu "F key" which is used to call the feature illustrated.

#### 7 Display field

Wheel type and rim dimensions  
Balancing modes  
Amount of unbalance  
Direction of orientation and correction position  
Function and Setup Menus

## 3.2 Menu Keys

### 3.2.1 Description of Menu Keys

The assignment of the menu keys **F1** to **F6** is shown in the menu fields above the relative keys on the screen. The menu keys have different functions and initiate different actions, depending on the program step.

- Keys without a symbol in the upper right-hand corner or at the edge initiate an action immediately such as **F2** on the main screen means to perform a compensation process. See Figure 13.
- Keys with one or more symbols in the upper right-hand corner of the menu field or at the edges initiate various actions:

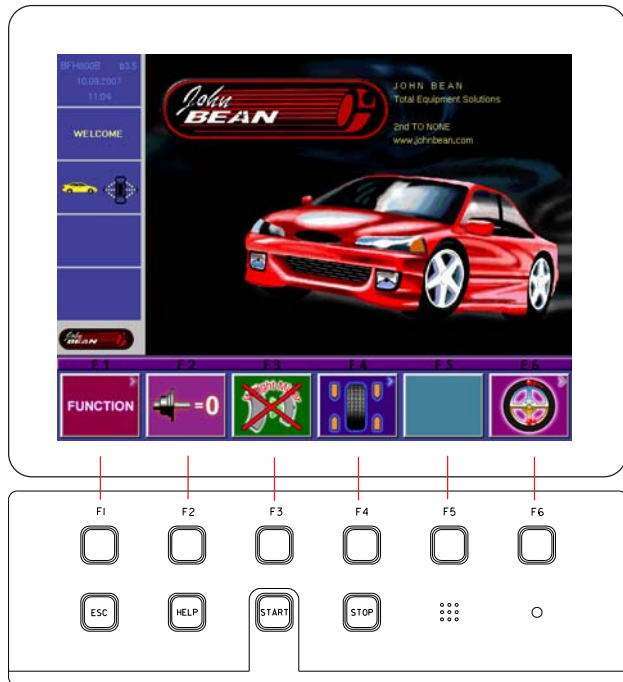

Figure 13

**a** - Press key to access a sub-menu, e.g. key **F 4** Balancing.

**b** - Press and hold key down while rotating wheel at same time, e.g. key **F11** Number of spokes.

**c** - Press key to toggle between two options or states, e.g. key **F9** Static / dynamic unbalance.

**d** - Press key to toggle between several options or states, e.g. key **F 21** Weight position for correction plane.



a b c d

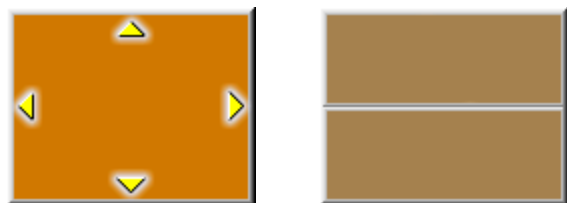

e f

**e** - Toggle switch (4 functions): Press edge of key to carry out the highlighted action, e.g. key **F 32** Character set: move the cursor in the character set to the left, to the right, up or down.

**f** - Toggle switch (2 functions): Press key on top or bottom to select the highlighted function, e.g. key **B** Precision reading of unbalance and mode select.



Icon 1

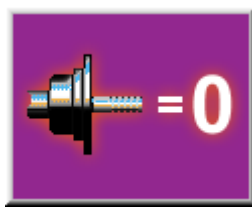

Icon 2



Icon 3

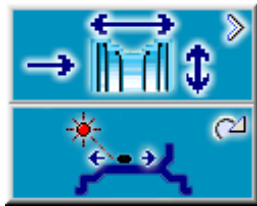

Icon 5



Icon 6



Icon 7a



Icon 7b



Icon 8



Icon 9



Icon 10

### 3.2.2 MAIN MENU FUNCTIONS

**Icon 1** Change to the Function screen

**Icon 2** Perform adapter compensation run

**Icon 3** Change to the Balancing screen

### 3.2.3 BALANCING

**Icon 5** Toggle switch, two functions:

Pressed on top:  
View and/or edit Data Input (wheel parameters)

Pressed on bottom:  
Move the laser position pointer to the desired location. Button must be held down as the shaft is rotated. (only when stick-on weights are selected)

**Icon 6** Toggle switch, two functions; reading only as long as the key is pressed (quick reading):

Pressed on top:  
Precision reading of unbalance, no suppression of minor unbalance readings.

Pressed on bottom:  
Toggles through possible placement locations of weight placement for conventional balancing run.

**Icons 7a and 7b** Select static unbalance or Select dynamic unbalance

**Icon 8** Number of spokes has been selected and entered.

**Icon 9** Number of spokes has not been detected.

1. Press and hold F5 and turn the wheel to enter the number of spokes.
2. Release F5 when the right number of spokes is indicated.
3. Turn the wheel in the way that one spoke is located on the 12 o'clock position.
4. Press F5 and the balancer will split the weight into 2 pieces.
5. Place the weights behind the spokes.

**Icon 10** Wheel with 6 spokes selected

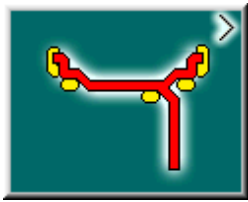

Icon 11



Icon 12

### 3.2.4 RIM DATA INPUT

**Icon 11** Change to the WEIGHTPLACEMENT (mode) screen.

**Icon 12** Change to the RIM TYPE screen



Icon 13

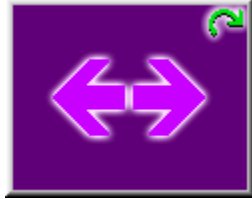

Icon 14

**Icon 13** Hold key down and enter the distance rim/machine by rotating the wheel

**Icon 14** Hold key down and enter the rim width by rotating the wheel



Icon 15

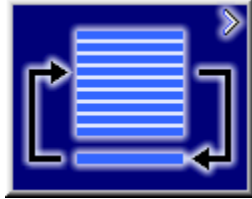

Icon 16

**Icon 15** Hold key down and enter rim diameter by rotating the wheel

**Icon 16** Change to the Stored Parameter menu. Must be in the "Manual" parameter mode

### 3.2.5 PROFILES SCREEN, STORED PARAMETERS



Icon 17



Icon 18

**Icon 17** Select or store a wheel profile. Hold key down and select copy or store by rotating the wheel.

**Icon 18** Store a parameter. Select memory location to store current wheel profile for later retrieval (yellow arrow). Select "OK" to enter the values currently in use to a stored location.



Icon 19

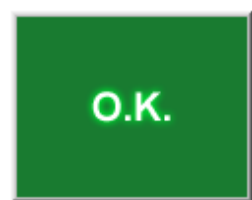

Icon 20

**Icon 19** Copy a stored parameter. Select memory location for retrieval (yellow arrow). Select "OK" to enter the values stored for use in the next balance run.

**Icon 20** Accept or enter the selected parameters.

### 3.2.6 FUNCTION MENU



Icon 21



Icon 22

**Icon 21** From the Main Menu, Select FUNCTION to access screens used to prepare the unit for desired operation.

**Icon 22** Change to the screen USER CALIBRATION, see Maintenance chapter for user calibration procedures.



Icon 23

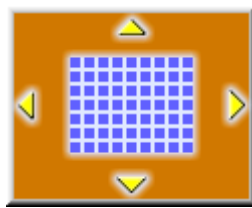

Icon 24

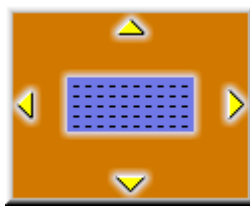

Icon 25

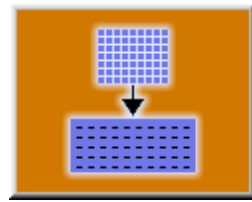

Icon 26



Icon 27

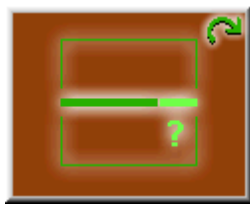

Icon 28



Icon 29

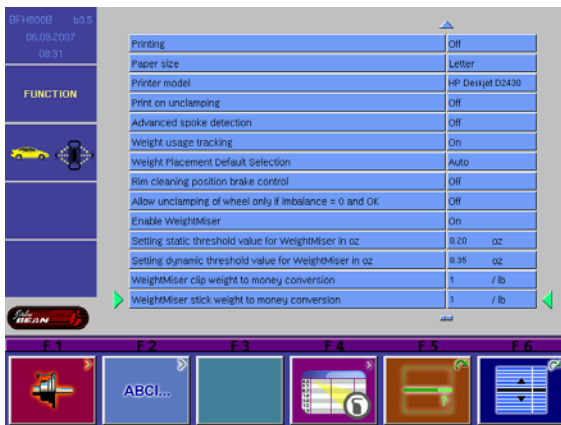

Figure 14

### 3.2.7 TEXT EDITOR

**Icon 23** Change to the screen TEXT EDITOR

**Icon 24** Toggle key, four functions: Move the cursor within the character set (right, left, up, down) to the desired character.

**Icon 25** Toggle key, four functions: Move the cursor within the text field (right, left, up, down) to the desired text box location

**Icon 26** Transfer characters from the character set to the text field

**Icon 27** Save text

### 3.2.8 FUNCTION (SETUP)

**Icon 28** Change selected topic to desired value or function.

**Icon 29** Hold button and rotate the wheel to scroll up or down to the desired line item.

Setup screen illustration. When desired features have been selected, save to permanent memory by selecting line item "3", Save to Permanent memory enter a value of "1" with the F5 button while rotating the shaft. Release button to save. Select the "ESC" button to return to the main screen. See Figure 14.

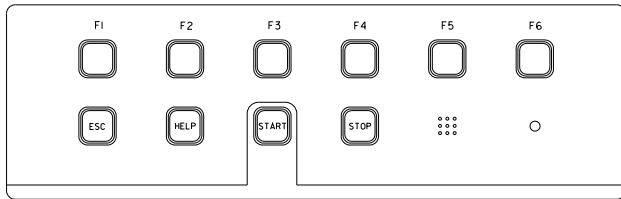

Figure 15

## 4.0 Help information

Help information explains the current action and, in the case of an error code, provides hints for remedy. See Figure 15.

### Display help information

- Press the HELP key ( See Figure 16)
- The first screen with help information appears, e. g. to the screen RIM DATA INPUT.
- Press the HELP key once more to display any additional screen with information.

### Quit help information

- Press the ESC key

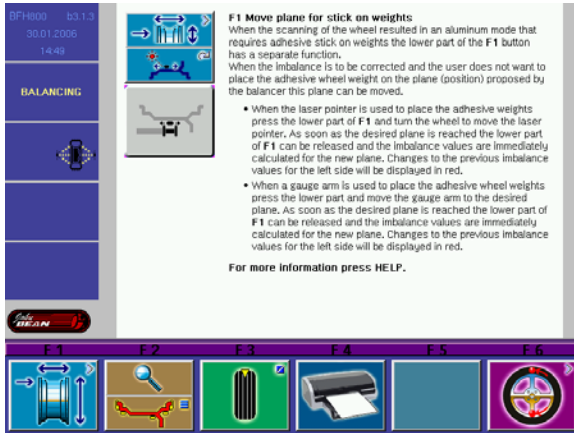
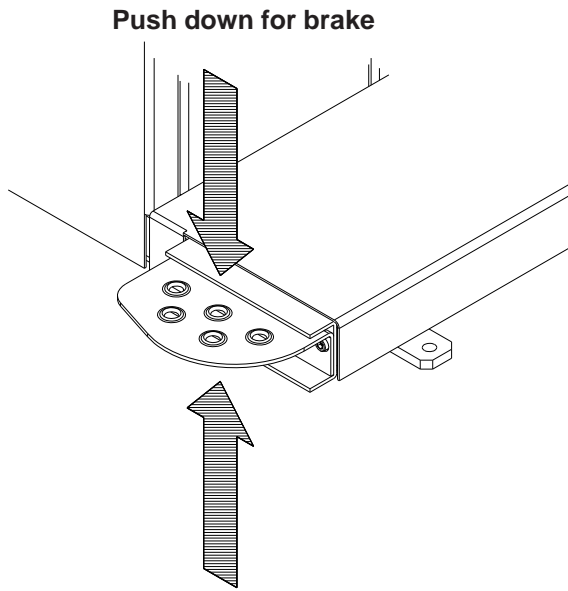

Figure 16



Lift up for power clamp operation  
Figure 17

## 5.0 POWER CLAMP

### 5.1 POWER CLAMP PEDAL

#### Shaft Lock

The main shaft is locked when the pedal is depressed. This holds the wheel in the correction position for correct fitting of the correction weights. See Figure 17.

This lock is designed only to facilitate orientation of the wheel and must not be used for braking the main shaft

#### Power Clamp Operation.

Lift upward to engage the power clamp jaws when the lock nut is placed on the shaft.

Lift upward again to release the clamp nut.

**NOTE:** The first time the unit is operated after power-up, make sure the power clamp engaging jaws are in the outer most position and ready for use. An Error of "E14" may result if the unit cannot accurately determine the clamping jaw position. Simple press "ESC" to continue, lift the pedal again to cycle and the power clamp will learn its new position. See Figures 18 and 19.

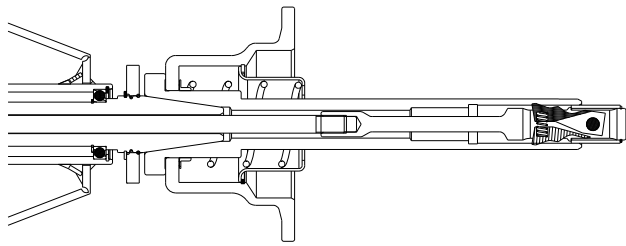

Power Clamp with jaws all the way OUT

Figure 18

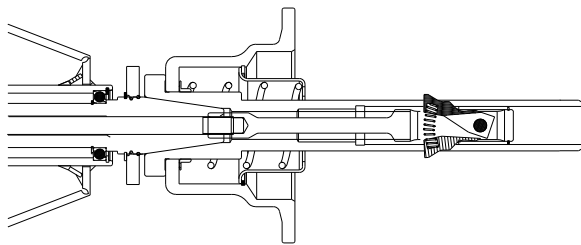

Power Clamp with jaws all the way IN

Figure 19



**SEVERE PERSONAL INJURY WILL OCCUR  
IF FINGERS OR HAND IS PINCHED  
BETWEEN THE NUT, WHEEL OR FLANGE**

## 6.0 OPERATION OF THE BALANCER

**WARNING:** For operator safety please read and follow the precautions outlined on pages 1 and 2 of this manual.

**NOTE:** READ ALL INSTRUCTIONS BEFORE PROCEEDING WITH OPERATION OF THE BALANCER.

All balancer functions are input into the main computer through the large easy to read touchpanel. Although each wheel tire assembly differ in some ways all balancing jobs require basically the same procedure. The order of events to take place are:

1. Inspection of the wheel/tire assembly
2. Mounting wheel onto shaft
3. Scanner entry of wheel profile
4. Applying the recommended weight
5. Check spin if desired
6. Dismounting the wheel

The following operation instructions will follow the basic outline above.

### 6.1 CHECK LIST - INSPECTION

#### Observe Before Balancing Wheel

1. Check for proper air pressure. If not correct, inflate to correct pressure.
2. Check for any foreign material inside tire. If present, remove before balancing tire.  
*WATER IS FOREIGN MATERIAL!*
3. Remove old weights — old weights may be improper value or in wrong location.
4. Be sure tire and wheel are free of excessive dirt, rust and large stones. Use wire brush on back side of wheel if necessary.

Figure 20



5. From the main menu, see Figure 20 above, select the desired process  
F1. Function - setup the balancers parameters to perform in a certain fashion  
F2. Compensate a wheel adapter  
F3. Select to operate in the 'Optional Weight Miser™' mode or not  
F4. Go to the balance process - normal selection for most users  
F5. Not Used  
F6. Optima - optimization process

## 6.2 BALANCE SCREEN DESCRIPTION

Refer to Figure 21a below for an example of a typical balance screen. The wheel displayed has been profiled as a rim which will accept a clip weight on the left side and a stick-on weight on the right side. The Clip weight will be placed at top dead center when the arrows indicate green. The stick-on weight is placed as indicated by the laser pointer. The operator selects the desired mode as indicated by the yellow weight icons, such as clip-stick as shown in the example below. Subsequent wheels will use the same mode until a different profile or parameter is detected.

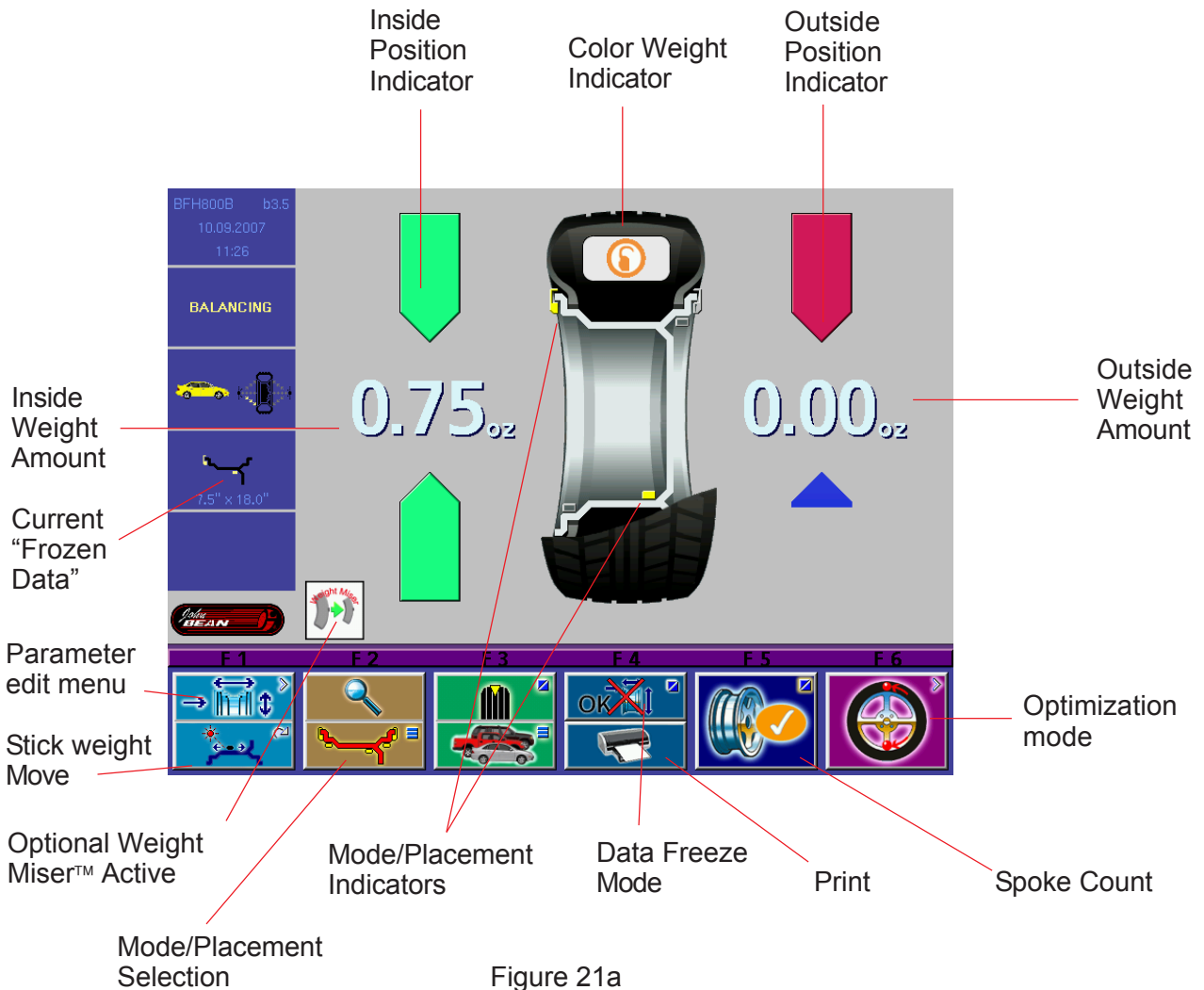

Figure 21a



Figure 21b - Color Weight Selections

## Begin Balance procedures

From the Main Menu, select "F4" to enter the balance mode of operation.

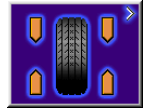

### 6.2.1 WHEEL MOUNTING

Most standard wheels and many alloy wheels have accurately machined center holes, and they should be mounted with center cones. Accurate balancing depends on accurate mounting of the wheel and correct seating of the cone in the pilot hole. Insure that the wheel is centered on the shaft exactly as it will be mounted to the vehicle.

Before starting any balancing procedure it is very important that the wheel is mounted on the machine with the proper adaptors. An incorrect centering of the wheel will result in considerable imbalance.

There are many types of wheels and John Bean supplies adaptors of high quality and durability for the large majority. However if you meet special wheels which may require a specific adaptor call your authorized John Bean distributor.

Rims may be divided into these major groups:

1. *Car rims with a true center hole.*
2. *Car rims without a center hole.*
3. *Car rims with an untrue center hole.*
4. *Light truck rims.*

### 6.2.2 STANDARD WHEELS (BACK CONE MOUNT)

Mount the wheel as detailed below in Figure 22a.

1. Mount proper cone against spring plate.
2. Mount wheel on shaft in the same manner as you would on the car.
3. Mount the Power Clamp nut along with proper pressure cup.
4. To operate the power clamp, lift the foot pedal to engage the clamp. Lift pedal again to release the nut.

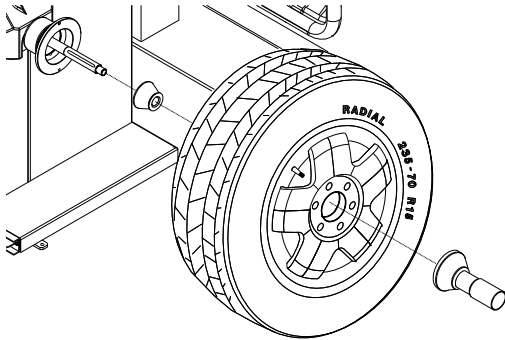

Figure 22a - Standard rear cone mount

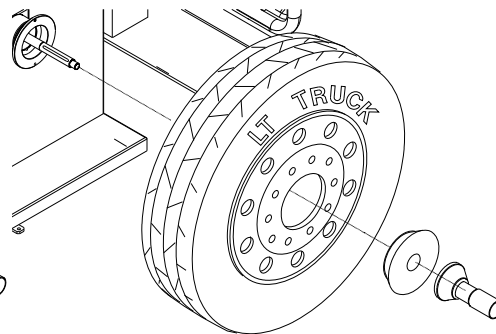

Figure 22b - Truck cone - outside cone mount

### 6.2.3 CENTERING LIGHT-TRUCK WHEELS

Install the wheel, using the front cone method, See Figure 22b.

An optional offset spacer may be required for some light truck wheels and reverse-offset wheels that must be moved away from the balancer mounting flange. The extension adaptor is often used with the 5-1/4 inch diameter light truck cone.



**WARNING - HOLD THE POWER CLAMP NUT BY THE PLASTIC END CAP ONLY!! THE POWER CLAMP WILL NOT STOP UNTIL THE WHEEL IS SECURE AGAINST THE FLANGE. SEVERE PERSONAL INJURY WILL OCCUR IF FINGERS OR HAND IS PINCHED BETWEEN THE NUT, WHEEL OR FLANGE.**



### 6.3 SCAN MODE SELECTION

The BFH 800 can be operated in 2 modes, Automatic Profiling and Manual Mode. Default factory setting is the Profiling mode.

**PROFILING** mode features fully automatic rim profile and parameter entry including:

- Rim profiling to get rim data including ALU wheel weight position
- Spoke count when ALU mode is detected
- Balancing



The PROFILING mode is indicated by the following symbol that is visible in information box 3 in the left upper corner of the screen.

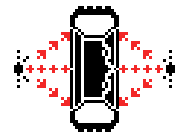

**MANUAL PARAMETER ENTRY MODE** - Read the rim diameter marked on the sidewall of the tire (Figure 23). Enter the rim parameters manually by pressing the parameter button twice then holding while rotating the wheel assembly until the desired value is displayed. Repeat for desired values for Distance, Width and Diameter. See Figure 24.

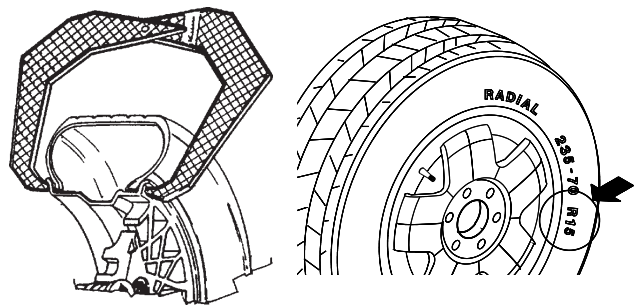

Figure 23



Figure 24

#### 6.3.1 DATA FREEZE MODE

After spinning the first wheel of a multiple set of wheels, Press F6 in the Parameter Screen to “Freeze” or store the wheel data. The Data Freeze feature is accessed by selecting the top part of F4 on the Placement Screen. This time saving feature allows subsequent wheels of like style and size to be balanced without taking the time to Profile the wheel. Simply press F9 again to service wheels that require a new profile.

### 6.4 SPINNING THE WHEEL

**CAUTION:** Before spinning the wheel, make sure proper eye protection is worn by all personnel in the vicinity of the balancer.

Spin the wheel by lowering the wheel guard. If auto-spin is not activated press **Start** to begin balancer run. When the balancing cycle is complete the wheel will stop automatically and the imbalance values will appear on the screen.

In the Profiling Mode, the profilers automatically measure the rim distance, rim width, wheel diameter and measures the amount of imbalance. Spokes are counted as well. The rim edge is analyzed for selecting the type of weight to be used.



The BFH 800b then displays the correction screen for weight placement.

## 6.5 SELECTING THE WEIGHT PLACEMENT

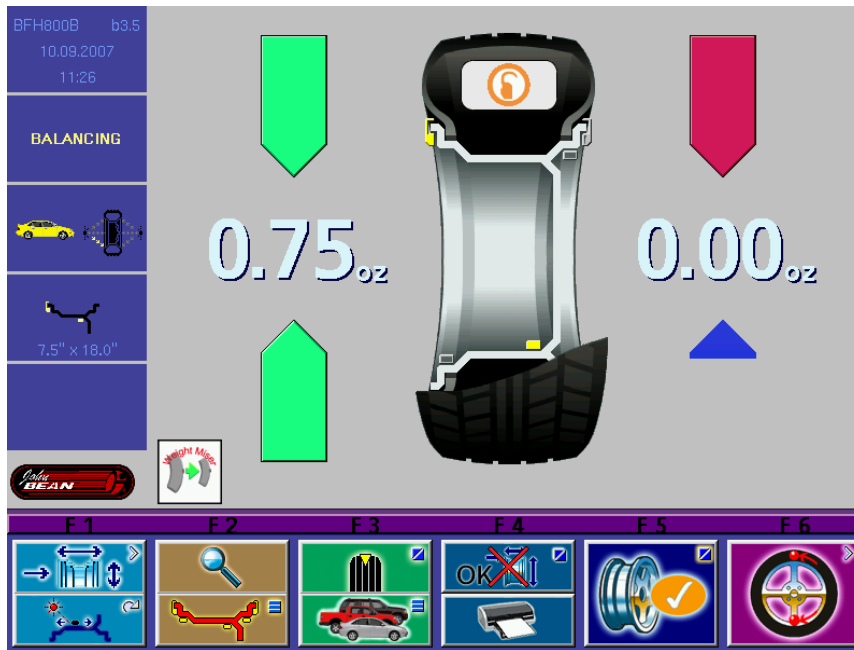

Figure 25

**A. 2-Plane** - Choose the appropriate balancing mode for the wheel. To select the various 2-plane weight placement modes press the Mode button (Lower part of F2) until the placement graphic indicates desired corrective weight placement position. Press and hold the lower button for 3 seconds goes directly to clip-clip without having to prompt through all the modes. Fig 25

**B. STATIC** mode. Use a single corrective weight placed in the center or inner edge of rim. Selected by pressing the "F3" key on the balancing screen. Pressing "F3" again will toggle operation back to Dynamic 2-plane operation.

**NOTE:** If in the "clip-weight static mode", the weight placement position will be at top dead center. While in "stick-on mode", weights will be placed at bottom center where the laser indicates.

## 6.6 CORRECTION OF THE IMBALANCE

**A.** The wheel assembly automatically stops near the right weight correction plane.

**NOTE:** Automatic plane braking can be selected from the Main Function Setup Menu. Factory default is right plane (2), select a value of "1" for braking on the left plane, "0" for none.

**B.** Read the imbalance value of the right side. Values are displayed in ounces but can be displayed in grams if required and are automatically rounded to the nearest commercial wheel weight.

**C.** Place the amount of weight called for. Use the foot operated shaft lock to stabilize the shaft during weight placement if required.

**D.** Press "Start" with the hood up to rotate the assembly to the left or inner correction plane.

**E.** Place the amount of weight called for. Use the foot operated shaft lock to stabilize the shaft during weight placement if required.



F2



Static

**NOTE: If a check spin reading does not “ZERO”, check for proper wheel mounting, weight placement, worn or damaged mounting accessories, or water in the tire etc.**

## PROCEDURE WHEN SCANNER FAILS TO ACQUIRE A VALID PROFILE



If data for distance, diameter or width are missing it is not possible to balance a wheel since the balancer does not have proper wheel data.

The unit will display the data (distance / diameter / width and weight placement mode) of the last valid wheel measured in RED color to indicate those data fields which might not be correct.

In the event of chasing weights, view the “Parameter” Screen and observe the values. If any parameter is displayed in red, it has not been validated and the value must be manually entered to recalculate the proper correction values. To change a value in the Parameter or Optima mode, the corresponding button must be depressed twice. Modify the data by pushing and holding F3, F4 or F5 and turning the wheel until the desired value is displayed.

After the wheel has been unclamped from the balancer the balancer will switch back to the previous mode for the next wheel assembly.

## 6.7 VERIFICATION OF THE RESULTS

Lower the wheel guard to spin the wheel again and check that the readout is “0.00” “0.00” If a residual imbalance is displayed: Reference Graphic 1 next page for diagnostics explanation below

**NOTE:** Make sure the intended balance mode is selected, If Optional Weight Miser™ is selected a small amount of residual un-balance is expected. If the balance requires further attention, disable the Optional Weight Miser™ mode

- A.** Check the rim parameters, if entered value is incorrect, correct as needed. Imbalance values will be automatically re-computed.
- B.** Check if the balancing mode selected is the most appropriate. If not, choose the right mode and re-spin.
- C.** The wheel weight could have been placed at a wrong position. To check this, position the wheel at the correction position for the outer plane. If the wheel weight previously attached is in sector **L** or **R** ( Graphic 1, page 20), move the wheel weight up about 1” (2.54cm).

If the wheel weight is in sector **D** cut a piece of the wheel weight of an approximate value corresponding to the value shown on the right display or replace the wheel weight with a lighter one.  
If the wheel weight is in sector **U** add a weight of value indicated by the display or replace the wheel weight with a heavier one. Repeat the same operation for the inner plane.

**NOTE:** If this situation is repeated, your machine may be out of calibration and a calibration operation might be required, contact a service representative for re-calibration.

- D.** If an *ALU* function was selected ensure the wheel weights have been placed in accordance to the program chosen.

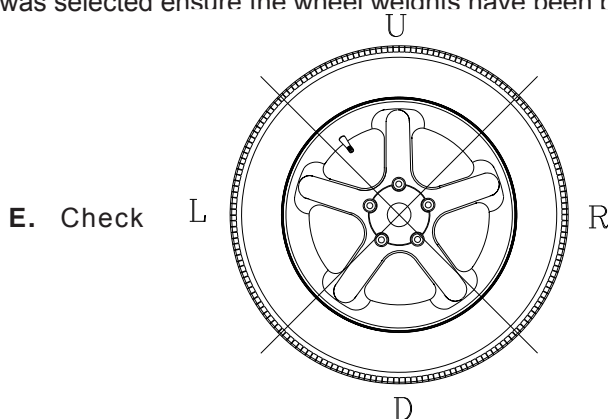

E. Check

---

that the wheel is not slipping against the backing collar  
F. Check that the wheel and adaptors are clean.

Graphic 1.

## 6.8 VIBRATION PROBLEMS

If vibration is still present after balancing, check the following possible sources of vibration:

1. Stones caught in the tire tread.
2. Tire slippage on the wheel.
3. Incorrectly mounted wheel.
4. Imbalanced wheel covers.
5. Excessive radial or lateral runout in the tire or wheel.
6. Damaged wheel bolt holes.
7. Worn universal joints.
8. Imbalanced brake rotors or drums.
9. Worn or damaged balancer accessories.

## 7.0 SPOKE BALANCING MODE

A standard dynamic balance in ALU mode places compensation weight in two planes, inner and outer , at the bottom dead center for each plane of calculated imbalance. Sometimes the outside weight placement may be unsightly on a custom wheel. The Spoke Mode is designed to “hide” outer plane corrective weight by placing the required weight behind selected spokes in order to retain the esthetic appeal of the wheel.

1. Press the Spoke button, F5.
2. Outer weights will be divided. Weights may not be equal depending on the spoke positions relative to the imbalance position.
3. Place stick-on weights where indicated by the laser pointer
4. Perform a check spin if desired.

**NOTE:** *Stick-on weight position can be “tweaked” by depressing the lower part of “F1” while rotating the shaft fore or aft until the laser locates in the desired position. Inner or Outer placement indicator must be “in the green” before depressing the button.*



Figure 26

## 8.0 Optimisation Procedures

1. Optimisation is a tire - rim matching procedure used to minimize placed weight. This matching procedure can also minimize radial runout in many cases where the runout high point is associated with the measured heavy point. The Optimisation procedure can begin with a bare rim or by starting with a tire/rim assembly.

Select softkey "F6" to continue to the matching process. See Figure 26.



Figure 27

2. From the Screen displayed in Figure 27, select "F5" to begin matching a tire/rim assembly, select "F6" to begin the matching process with a bare rim.

The example procedure shown will select a tire/rim assembly.



Figure 28

3. Rotate the assembly so the valve stem is located at top dead center. Press "F6", to continue. See Figure 28.



Figure 29

4. Press the “Start” button to begin a measure run. See Figure 29.

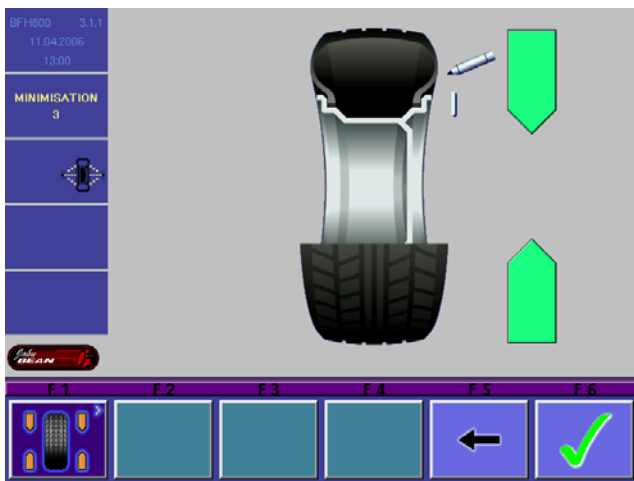

Figure 30

5. Rotate the assembly so the arrows are both GREEN, as shown in Figure 30. Mark the tire at top dead center. Select “F6” to continue.

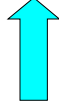

Figure 31

6. Remove the Wheel assembly from the balancer and break the bead using a tire changer. Rotate the tire on the rim so the mark and valve stem are lined up. See Figure 31. Select “F6” to continue.





Figure 32

7. Reinflate the tire to specifications.

Mount the assembly back onto the balancer as before.

Rotate the tire/rim assembly so the mark-valve stem is straight up, or at the 12:00 o'clock position. See Figure 32. Press "F6" to continue.



Figure 33

8. Select "Start" See Figure 33.

The unit will re-profile and recalculate based on the new tire-rim combination.

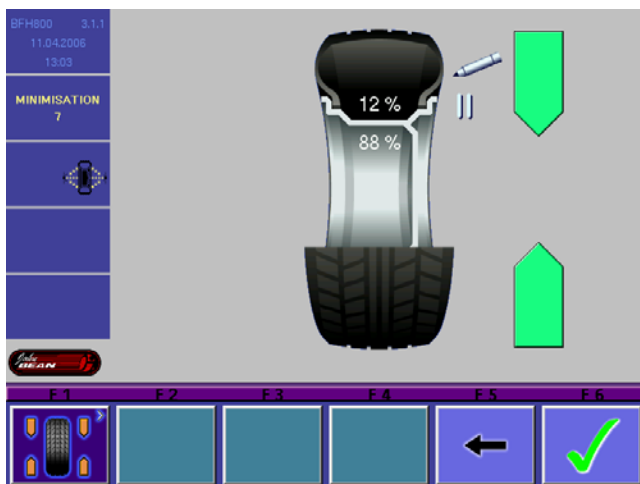

Figure 34

9. Rotate the assembly until the arrows turn Green as shown in Figure 34. Mark the tire with two (2) marks.

Select "F6" to continue.



Figure 35

- Remove the tire/rim assembly from the balancer and break the bead using a tire changer . Rotate the tire on the rim so the double mark and valve stem are lined up. See Figure 35.



Figure 36

- Reinflate the tire to specifications.

Mount the assembly back onto the balancer as before.

Rotate the tire/rim assembly so the mark-valve stem is straight up, or at the 12:00 o'clock position. See Figure 36. Press "F6" to continue.



Figure 37

- Select "Start" See Figure 37.

The unit will re-profile and recalculate based on the new tire-rim combination.



Figure 38

13. If the match procedure was successful an "OK" will be displayed as shown in Figure 38.

Press "F6" to continue to the balance screen for weight placement.



Figure 39

14. Corrective weight amounts and locations will be displayed. See Figure 39.

## 9.0 WEIGHT MANAGEMENT



**INTRODUCTION** - The BFH Series Weight Management Software features consist a unique program designed to maximize the tire shops profits while maintaining efficiency. **Weight Wizard™** works to reduce weight costs, and minimize excessive weight inventory. Weight inventory can be tailored by location requirements to avoid waste.

### Weight Wizard™

**Weight Wizard™** is a Patented method using a precision laser to determine the required clip weight type for the rim profile being serviced. The laser can also determine use of stick on weights and precisely place them for maximum performance. As wheel weights are changing from lead to steel due to environmental and health concerns and the cost of wheel weights increasing with the change. Customers can now purchase wheel weights in quantity with regard to weight type and weight amount. This will allow shops to avoid accumulating large quantities of unused wheel weights which are expensive to purchase and difficult to store.



### Viewing the Weight Wizard™ Data File:

From the Main Menu – select the F1 “Function Key”, from the Function Menu screen select the F4 Key to display the Weight Management screen. See Figure 40.



Figure 40

### Weight Wizard™ Features:

- ⊗ Weight Wizard™ indicates both what type of weight and weight sizes that are actually being used.
- ⊗ Knowing the most popular usage, the buyer can tailor the weight purchasing requirements by location and avoid excessive expense and waste.
- ⊗ The time and date of the tracking file is displayed across the top of the screen.
- ⊗ Weight amounts in quarter ounce increments are listed from one quarter ounce through four ounces on the left hand side.
- ⊗ Both an “Accumulated” and “Since this Date” counts are available by toggling “F3”. The “Since” values are reset by selecting “F2”. The Accumulated values must be reset by formatting via the Function Menu.
- ⊗ If tape on weight is used, the amount of tape on weight is also stored.
- ⊗ Weight amount and type is determined automatically by the wheel balancer
- ⊗ Upon un-clamping of the wheel, the weight type and weight amount is written to this file.



Figure 41



Figure 42

Optional Weight Miser™ is enabled

### Optional Weight Miser™ - 9.1

*Optional Weight Miser™* is a software program that determines if there is the possibility to remove sufficient vibration from a tire and wheel assembly by applying a lower amount of weight than the normal balance function recommends. The amount of residual imbalance left on the tire and wheel assembly is determined by the residual threshold tolerance setting.

Assuming that an amount of residual imbalance accepted nowadays by the automotive industry standards is 5 grams for static imbalance and 10 grams for dynamic imbalance, a new feature *Optional Weight Miser* allows the tire shop to achieve wheel balancing using less – smaller – balancing weights.

It must be very clear that the feature works assuming that some residual imbalance can be left on the wheel. The tire shop will save weight, but wheels will be balanced with a lower degree of accuracy.

The feature – *Optional Weight Miser™* – is disabled by default when the unit is manufactured. The machine will leave the factory in its original high-accuracy balancing configuration.



Figure 43

Disabled

The user has the option to activate the feature from the “*Main Menu*”. See Figure 43. Press the “F3” key to activate *Optional Weight Miser*. The feature is activated when the green icon with the “X” is shown at the “F3” position as shown.

When in the *Optional Weight Miser™* mode, software determines if a single weight approach is feasible. If it is possible to reduce both static and dynamic imbalance below the given thresholds using a single weight, then a single weight will be recommended. If not, two-weight balancing will be recommended, but the weight amounts can be lower



Figure 44

There are five entries in the **Function Menu** for Optional Weight Miser™ setup. See Figure 45.

1. Optional Weight Miser™ feature enable – ON/OFF  
(Function default is OFF)
2. Optional Weight Miser™ static threshold
3. Optional Weight Miser™ dynamic threshold
4. Clip weight to money conversion
5. Stick weight to money conversion

The two thresholds for Optional Weight Miser™ are adjustable. There is a recommended pre-set limiter.



Figure 45

The Optional Weight Miser™ thresholds can be set in the set up function screen as described. Furthermore, a quick way to change thresholds is the vehicle type selection.

For the vehicle category – SUV and Truck, there is a multiplier that increases the threshold from the preset **CAR** values due to the fact that these vehicle types can tolerate a higher residual imbalance. See Figure 43.

<u>Vehicle type</u>	<u>Threshold</u>
Passenger Car	1x
Motorcycle	1x
SUV	1.5x
Light Truck	2x



Figure 46

The weight to money conversions are adjustable to display the approximate amount of money savings relative to the weight savings. The user can change the value of conversion depending upon his weight purchase costs

To observe the Optional Weight Miser™ screen as shown in Figure 44, press the F5 button when in the Weight Wizard™ screen.

## 10.0 USER CALIBRATION

The BFH 800 Balancer features a user calibration program which requires only a few minutes to complete. Perform this procedure when the balancer has been moved, disturbed, or whenever accuracy is questioned. Occasional field calibration will ensure years of reliable service.

Follow these 3 simple steps for shaft calibration:

1. Press and release the “**Function**” key (F1) from the “Welcome or Main Screen”.
2. Press and release the “**Calibration**” key (F1). Fig 47.



Figure 47

3. Place 2 cones followed by the clamping nut (no retainer) onto the shaft. Lift the pedal to clamp. See Figure 48.

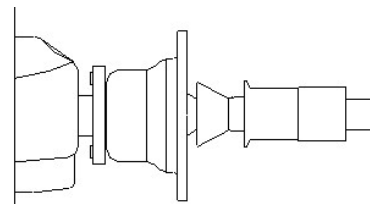

Figure 48 - 2 cones & clamping nut only

4. Lower the wheel guard and press the “**SPIN**” key. The balancer should spin and come to a complete stop. See Figure 49.

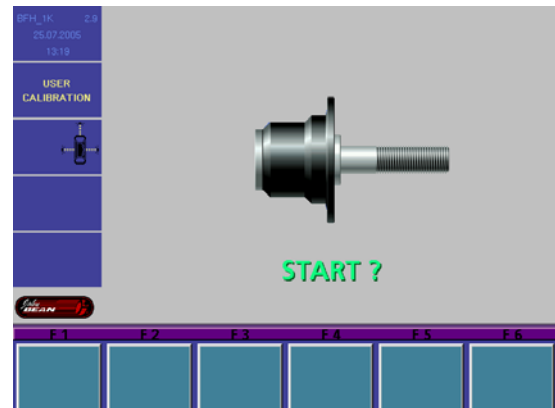

Figure 49

4. After the balancer comes to a stop raise the wheel guard and screw the calibration slug into left side of the flange plate. Lower the wheel guard and press the “**SPIN**” key. The balancer should spin and come to a complete stop. Once the shaft stops the display should display “OK” and the speaker sounds the Snap-on “TüDüLü”. See Figure 50.

### SHAFT CALIBRATION IS COMPLETE

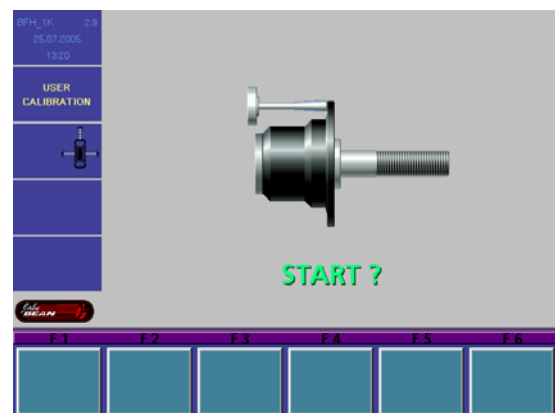

Figure 50

---

## 11.0 EXPLANATION OF PROGRAM CODES

In the event of damage or malfunction, a code may be displayed indicating the area or location of the detected error. These codes are important to the service agent when he services the unit. Note any codes or error messages before calling for service or assistance.

- 1. Communication between micro-controller and embedded PC (Blue screen)**  
Service Codes: No service code available Communication between micro-controller and embedded PC is not OK (check connecting cable). This can also indicate a bad connection to the keyboard.
- 2. Check availability of keyboard (E 300)**  
Service Codes : No service code available The microcontroller was not able to detect a keyboard. Check cabling between microcontroller and keyboard.
- 5. Check keyboard (E 89)**  
One of the keys F1 to F6, HELP, ESC, START supplies a "Stuck key" code. The machine will proceed with the next step only if the trouble is remedied.
- 6. Check pedal switches (E 89)**  
Press STOP or ESC key to check the pedal switch once to delete the error code reading. If the trouble cannot be remedied, the pedal is made inoperative.
- 7. Check BFH Calibration (E 360)**  
The optima hardware requires wheel profiler position calibration.  
When the camera controller board is replaced on the machine, the SW detected that calibration data is missing. A Service Calibration procedure is required to calibrate the actual position of the laser scanners with respect to the balancer reference plane. Contact a Service Representative.
- 8. Check BFH Hardware (E 361)**  
Wheel profiler is not present or responding during the self test. The balancer controller board was not able to communicate with the camera controller board during startup test.  
Possible causes:
  - The camera controller board is missing or dead.
  - The cable connecting the balancer controller board and the camera controller board is unplugged, damaged or missing.
- 9. Check BFH Hardware (E 362)**  
Service Codes : All codes available for this model  
Main camera board self test failed.  
Balancing is not possible since wheel data cannot be scanned.  
Problem during power up. Switch power off and on again. Possible camera board failure.
- 10. Check BFH Inner Scanner (E 363)**  
Service Codes : All codes available for this model  
Left side scanner self test failed or CCD not calibrated or zero mark not detected.  
Balancing is not possible since wheel data cannot be scanned.
- 11. Power clamp service interval expired E93**



## **12. Hardware test disturbed H 82**

### **A. Hardware test -common errors**

**C10F02** -Test returned with an error. No valid test results available

**C10F07**-Test function reported an unknown error

**C10F18**-Test timed out. No valid test results available

### **B. Hardware test -Power supply voltage**

**C10800**

**C10801**

**C10804**

If the line voltage is below or above a limit the error code is displayed.

### **C. Hardware test -5V line**

**C10810**

**C10811**

If the 5V voltage is below or above a limit the error code is displayed.

### **D. Hardware test -Current of optoelectronic LED**

**C10705**

**C10706**

**C10707**

**C10708**

If the current / voltage is below or above a limit the error code is displayed.

### **E. Hardware test -Transducer signals**

**C10410**

**C10420**

**C10430**

Checks transimpedance and signal amplifiers and transducer values. If no signals from the transducers are detected the error code is displayed.

### **F. Hardware test -Auto stop system**

**C10380**

**C10381**

**C10382**

**C10383**

Checks voltage on capacitor of the auto stop system.

If the voltage is below or above a limit or the recharging time is above a limit the error code is displayed.

---

## 12.0 MAINTENANCE

**BEFORE ANY MAINTENANCE OR REPAIRS ARE ATTEMPTED THE MACHINE MUST BE DISCONNECTED FROM THE ELECTRIC SUPPLY.**

This balancer does not require any special maintenance, but the following precautions are required:

- A. Periodically clean all plastic parts with a glass cleaner. Wipe with a dry cloth.
- B. Clean all adapters regularly with a nonflammable liquid detergent all. Lubricate with a thin layer of oil.
- C. Periodically perform a routine shaft calibration as outlined on page 35 of this manual.

## 13.0 TROUBLE SHOOTING

<b><u>TROUBLE</u></b>	<b><u>CAUSE</u></b>	<b><u>REMEDY</u></b>
When turning the machine on, the displays do not light	No electric power Defect in the electric/electronic system	Check the input voltage Call the Equiserv service center for assistance
The machine gives random readouts.	Machine unstable on the floor Water in the tire Loose adaptor Defective electronic board	Check that machine is stable Remove water from tire. Tighten the adaptor firmly Call the Equiserv service center for assistance
The machine does not stop after balancing cycle	Defective electronic component	Stop using the machine immediately and call the Equiserv service center for assistance
The balancer is slow to display when powering machine up.	This machine performs a self-test routine on start-up. There will be a delay of several seconds before the display is activated.	This is a normal characteristic of the machine
If the balancer ceases to properly measure parameter values	Malfunction of one of the scanners, A failure of the AWP system, or harness connection failure.	Call the Equiserv service center for assistance



NOTES:



#### **USA**

Snap-on Equipment  
309 Exchange Avenue  
Conway, Arkansas 72032  
Tel.: (800) 362-8326 or (501) 450-1500  
Fax: (501) 450-1585

#### **UNITED KINGDOM**

UK Equipment Ltd  
48 Sutton Park Avenue,  
Reading RG6 1AZ  
Tel: +44(0) 118 929 6811  
Fax: + 44 (0) 118 966 4369

#### **LATIN AMERICA**

International Equipment Group  
309 Exchange Avenue  
Conway, Arkansas 72032  
Tel.: (501) 450-1526  
Fax: (501) 450-2086

#### **ITALY**

Snap-on Equipment s.r.l.  
via Prov. Carpi, 33  
42015 Correggio (RE)  
Tel: 39 0522 733600  
Fax: 39 0522 733610

#### **CANADA**

John Bean  
6500 Millcreek Drive  
Mississauga, Ontario  
Canada L5N 2W6  
Tel: (905) 814-0114  
Fax: (905) 814-0110

#### **FRANCE**

Snap-On Equipment France  
Za du Vert Galant  
15, rue de la Guivernone BP 7175  
95310 Saint-Ouen-L'Aumône  
Tel: +33 (0) 1-3448-5894  
Fax: +33 (0) 1-3448-5870

#### **GERMANY**

Snap-on Equipment GmbH  
Werner-von-Siemens-Str. 2  
64319 Pfungstadt  
Tel: +49 (0) 6157 12 600  
Fax: +49 (0) 6157 12 601

**Notice:** The information contained in this document is subject to change without notice. **Snap-on Equipment** makes no warranty with regard to this material. **Snap-on Equipment** shall not be liable for errors contained herein or for incidental consequential damages in connection with furnishings, performance, or use of this material.

This document contains proprietary information which is protected by copyright and patents. All rights are reserved. No part of this document may be photocopied, reproduced, or translated without prior written consent of **Snap-on Equipment**.



is a registered trademark of Snap-on Incorporated