

CHAPTER 3

CHECKOUT, CALIBRATION AND MAINTENANCE

GENERAL



This chapter will help determine if the unit is operating properly and if all electronic devices are working per specifications. Be sure to read the step first before performing the actual function. This will help prevent any type of errors that might occur.

UNIT CHECKOUT PROCEDURE

These sections will checkout the complete operation of the ECO Xtreme Recycling/Charge Station. Refrigerant in recovery tank is required. In order to determine the proper operation, follow the steps in order to determine correct operation. If any of the steps fail the checkout, **STOP** and correct the problem. Refer to Chapter 1 or Chapter 2 for troubleshooting.

1. Confirm panel valves are OFF. Ensure the red & blue tank hoses are correctly connected to the Recovery Tank. Open both Recovery Tank valves. Ensure the vehicle hoses are connected to the ports on the rear of unit.
2. Plug the ECO Xtreme into a 115VAC outlet, and turn on. Verify that the **LCD DISPLAY** is working.
3. Press the <UP> arrow until "**CHARGE**" is selected and press <ENTER>.
4. Turn the 3-way valve to Charge and watch the display. The amount will continue to rise until the pressures equalize. Close the valves. Press EXIT. Press NO.
5. Press the <UP> arrow until "**RECOVER**" is selected and press <ENTER>. Turn valves to Recovery Press <START>. The compressor should come ON. The gauges should slowly drop as the unit recovers the refrigerant from the hoses.
6. Once the low side gauge reads approximately **15" Hg**, turn the 3-way valves to OFF, and press the <EXIT> key. Press <NEXT> the compressor should shut off. "**DRAIN OIL**" will be displayed.
7. Verify that the low side gauge is reading approximately **15" Hg** and holding. If vacuum is lost, check for leaks. Press the <NEXT> key. Wait for purge to complete.
8. Press the <UP> arrow until "**VACUUM**" is selected and press <ENTER>. Timer will display 30 minutes, press <UP> or <DOWN> to change.
9. Press <START>. The compressor should come on (Vacuum Pump on a model EEAC318). The low side gauge should show increasing vacuum. Once the low side gauge reads approximately **25 to 29" Hg**, and press the <EXIT> key. The Compressor (Vacuum Pump) will shut off.
10. "CLOSE PANEL VALVES THEN PRESS NEXT" will be displayed (close the Panel Valves). Press <NEXT>. If vacuum is lost, check for leaks on the gauge assembly.

UNIT CHECKOUT COMPLETE

CALIBRATION PROCEDURE**R-134A SCALE (LOAD CELL)**

- **TOOLS REQUIRED:** 40 LBS. of Weight

NOTE *(-x-) Refers to the Pot Position; (x--) pot on the left, (-x-) pot in the middle, (--x), pot on the right.*

1. Unplug the ECO Xtreme from the wall outlet.
2. Place a jumper on J21 across pins 1-2 on the Control Board.
3. Remove the recovery tank from the scale.
4. Plug the ECO Xtreme Recycling/Charge Station into a 115VAC outlet. Turn the unit on, (Light will flash and "No Tank Present" will be displayed) ignore the error messages.
5. When the Main menu screen appears, press the <UP> arrow and <ENTER>.
6. Press the <UP> arrow until "lbs / kg" appears, Press <ENTER>.
7. Press <UP> or <DOWN> arrow for the desired units of measure. (kg requires a 20 kg weight, all others use a 40 pound weight).
8. Press <SAVE / EXIT>.
9. Press the <UP> arrow key until Redundant Scale Cal. appears. Press the <ENTER> key.
10. Adjust R82 (-x-) for a reading of 100 +/- 2 counts. Press <EXIT> key.
11. Press the <UP> arrow key until "Scale Calibration" appears. Press the <ENTER> key.
12. With all weight removed from the scale, adjust R137 (--x) for a reading of 100 +/- 2 Counts.
13. Apply 40 lbs. to scale. Press <Calibrate>. Press **Confirm**. Display should read 640 oz. +/- 1 oz.
14. With 40 lbs still on scale, connect the DMM black lead to J25. Connect DMM red lead to J26.
15. Press <EXIT>, <DOWN>, <ENTER>.
16. Adjust R86 (x--) for a DMM reading equal to voltage number in upper right corner of LCD, +/- .005 volts. Press <EXIT>.
17. Turn power off and remove Service Jumper.

CALIBRATION COMPLETE

PSIA TABLE

in Feet	28 inHg	29 inHg	30 inHg	31 inHg	32 inHg
0	13.8	14.2	14.7	15.2	15.7
500	13.5	14.0	14.5	15.0	15.5
1000	13.2	13.7	14.2	14.7	15.2
1500	13.0	13.5	14.0	14.4	14.9
2000	12.7	13.2	13.7	14.2	14.7
3000	12.2	12.7	13.2	13.7	14.2
4000	11.7	12.2	12.7	13.2	13.7
6000	10.8	11.3	11.8	12.3	12.8
8000	10.0	10.5	11.0	11.4	11.9
10000	9.2	9.7	10.1	10.6	11.1
12000	8.4	8.9	9.4	9.9	10.4
14000	7.7	8.2	8.7	9.2	9.7

Table 1, PSIA Conversion Chart for various Elevations and Barometric Pressures

R-134 TEMPERATURE CALIBRATION

TOOLS REQUIRED: Thermometer

1. Unplug the ECO Xtreme from the wall outlet. Place a jumper across J21 pins 1-2 on the Main CPU Board.
1. Plug the ECO Xtreme Recycling/Charge Station into a 115VAC outlet. And turn on.
2. Press the <UP> key until the Setup menu is selected, press the <ENTER> key.
3. Press the <UP> arrow until "TEMPERATURE CAL" screen appears.
4. Press the <ENTER> key. "TEMPERATURE CAL" page will be displayed.
5. Use the <UP> or <DOWN> keys so the top temperature matches the thermometer.
6. Press <Calibrate>. Press <Confirm> key to accept the new reading.
7. Lower temperature reading should match thermometer +/- 1 degree.
8. Press the <EXIT> twice.
9. Remove jumper on J21 pins 1-2.

CALIBRATION COMPLETE

PRESSURE TRANSDUCER CALIBRATION

TOOLS REQUIRED: Barometric Pressure Reading (Obtain from calling the local airport)

1. Unplug the ECO Xtreme from the wall outlet. Place a jumper on J21 pins 1-2 on the Main CPU Board.
2. Plug the ECO Xtreme Recycling/Charge Station into a 115VAC outlet. Turn the unit On.
3. Press the <UP> key until the Setup menu is selected, press the <ENTER> key.
4. Press the <UP> arrow until "PRESURE CALIBRATION" appears on the screen.
5. Disconnect yellow hose from Recovery Tank.
6. Press the <ENTER> key. Press <UP> or <DOWN> as needed until set point value (upper reading) matches the value on PSIA Conversion Table nearest your barometric pressure and altitude.
7. Press <CALIBRATE>. Press <CONFIRM> key to accept the new reading. Press <EXIT>. Remove jumper on J21 pins 1-2.

CALIBRATION COMPLETE

CONTRAST ADJUSTMENT

1. Plug the ECO Xtreme Recycling/Charge Station into a 115VAC outlet. And turn the unit On.
2. Press the <UP> key until the Setup menu is selected, press the <ENTER> key.
3. Press the <UP> arrow until the LCD screen appears. Press <ENTER> key.
4. Press the <UP> or <DOWN> keys until the desired, brightness is achieved, or press <DEFAULT>.
5. Press <EXIT> twice to return to the main menu.

ADJUSTMENT COMPLETE

MAINTENANCE PROCEDURES

MASTER FILTER MAINTENANCE

FILTER KIT: EAK0030C01AB

NOTE *Change the master filter when the "Replace Filter" is displayed. For more information on tracking, refer to Appendix C Users Manual.*



WARNING!

USE STANDARD REFRIGERANT HANDLING
SAFETY PROCEDURES WHEN PERFORMING INSTALLATION

ALWAYS WEAR SAFETY GOGGLES, DON'T SPILL OR TOUCH
LIQUID REFRIGERANT, AVOID FLAMES, AND EXCESSIVE HEAT.
USE ONLY IN WELL VENTILATED AREA.

1. Evacuate service hoses. Refer to the User's Manual for location of the Filter Dryer.
2. Remove the power cord from wall outlet.
3. Slide the master filter out from the storage bracket.
4. Unscrew the two hose fittings from the master filter. Remove the master filter.
5. Install the new Filter Dryer and verify that the arrow on the Filter Dryer is pointing in the same direction as the arrow on the underside of cabinet.
6. Oil the end of the hoses that were removed from the Filter Dryer with Mineral Oil or Super Lube, and reconnect to the Filter Dryer.
7. Plug the unit into the AC wall outlet. Turn the unit On.
8. Press the <UP> key until the Setup menu is selected, press the <ENTER> key.
9. Press the <UP> arrow until "FILTER" is selected.
10. Press <ENTER>. Press <RESET>. Press <CONFIRM>. Press <EXIT>.

MASTER FILTER MAINTENANCE COMPLETE

COMPRESSOR OIL REPLACEMENT

OIL KIT: EAK0029C01AB

TOOLS REQUIRED: Torque Wrench

NOTE *The oil in the compressor assembly must be changed quarterly.*

1. Perform a Recycle on the service hoses, if necessary. For additional information, refer to Chapter 2 (User's Manual) Evacuating Service Hoses.
2. Unplug unit from AC wall outlet.
3. Remove screws securing plastic cover.
4. Remove the metal cover.

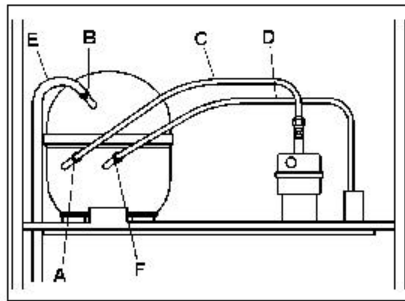

Figure 3-1 Compressor

A – Outlet Line Connection at Pump
 B – Input Line Connection at Pump
 C – Outlet Line (Tube)
 D – Process Line (Tube)
 E – Input Line (Hose)
 F – Process Line Connection at Pump

5. Disconnect all tubing and electrical connections from the pump making note of their locations.
6. Discard the old O-rings from hose tube ends if possible.
7. Discharge capacitor. Remove the four nuts holding the pump to the base. Remove all electrical connections from the pump. Remove the pump from the unit.
8. Tilt the pump over an oil drain pan so the process port (Top) is straight down. Oil will drain from this port. Approximately 9oz. of oil should be recovered. (This will take approximately 1 hour)
9. If around 9 oz. of oil is not recovered, repeat step 8.
10. Use plastic bottle supplied with oil change kit to pour 9.3 oz (275 cc) of 3GS compressor oil, part number 0681-0179-2, into input port of pump (top port). Or connect hoses and use the input hose to draw in the oil.
11. Reinstall the pump and secure using four nuts at the base.
12. Install new O-rings on ends of the tubing and hose assemblies.
13. Place a small amount of compressor oil on O-rings and reinstall tubing assemblies. Torque to 65-in. lbs.
14. Reinstall electrical connections.
15. Replace covers and secure.

VACUUM PUMP OIL

- Use standard Vacuum Pump Oil for lubrication.
 - Vacuum Pump oil level should be monitored to a level half way through the sight glass on the pump. Refill as needed.
 - The oil in Vacuum Pumps should generally be changed every 90 days.
1. Remove Drain plug from bottom of Vacuum Pump and allow oil to drain into appropriate container.
 2. Replace drain plug and remove fill plug at top of Vacuum Pump.
 3. Using Vacuum Pump Oil Kit (EAK0227L01A) remove cap from oil bottle and replace with Screw-on Spout Cap.
 4. While looking at the sight glass on the side of the Vacuum Pump, pour oil into the fill hole until oil level reaches half way up the sight glass.
 5. Replace fill plug on Vacuum Pump and cap on oil.

MAINTENANCE COMPLETE