

John
BEAN
Company

600 Series
Disk and Drum Lathe
Operators Manual

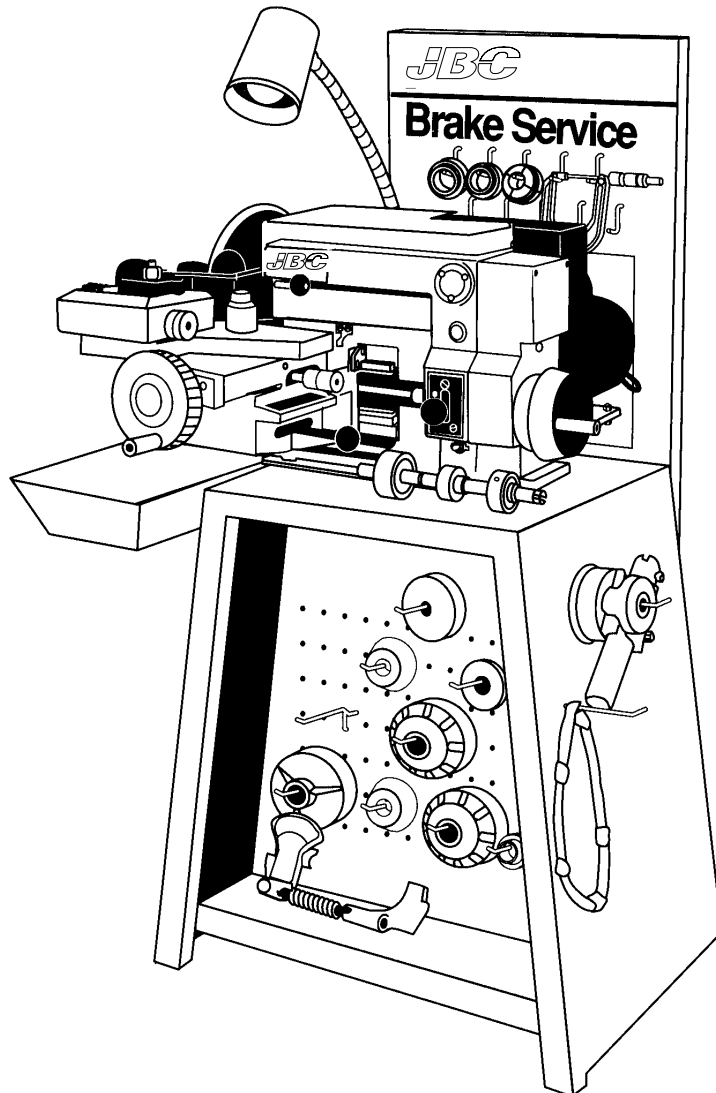

FORM 3804-11

CHECK LIST

1. Standard equipment is shown on page 3.
2. Optional accessories are available from your John Bean Dealer. You may also order by contacting John Bean Company, Exchange Ave., Conway, AR.72032 or by calling 1 - (800) 362-8326
3. Assemble deluxe bench if ordered. The lathe can be mounted on either when removed from the carton.

SAFETY INSTRUCTIONS

Warning!

For Your Own Safety, Read Instruction Manual Before Operating Lathe

1. Lathes are supplied with a three-wire cord to provide grounding if your electrical system is properly installed by a qualified electrician and in compliance with the national, regional and local electrical codes.

2. Improper grounding can cause electrical shock. In the event of a malfunction or breakdown, grounding provides a path of least resistance for electrical current to reduce risk of electric shock.

GROUNDING INSTRUCTIONS

All grounded, cord-connected tools: The lathe is equipped with an electric cord having an equipment-grounding conductor and a grounding gap. The plug must be plugged into a matching outlet that is properly installed and grounded in accordance with all codes and ordinances.

Do not modify the plug provided with domestic lathes - if it will not fit the outlet, have the proper outlet installed by a qualified electrician.

Improper connection of the equipment grounding conductor can result in a risk of electric shock. In the U.S.A., the conductor with insulation having an outer surface that is green with or without yellow stripes is the equipment-grounding conductor. If repair or replacement of the electrical cord or plug is necessary, do not connect the equipment-grounding conductor to a live terminal.

Check with a qualified electrician or serviceman if the grounding instructions are not completely understood, or if in doubt as to whether the tool is properly grounded.

Lathes sold and installed in the U.S.A. should use only 3-wire extension cords that have 3-prong grounding plugs and 3-pole receptacles that accept the power plug.

Repair or replace damaged or worn cords immediately.

This tool is intended for use on a circuit that has an outlet that looks like the one illustrated in Sketch (A) below. The tool has a grounding plug that looks like the plug illustrated in Sketch (A) above. A temporary

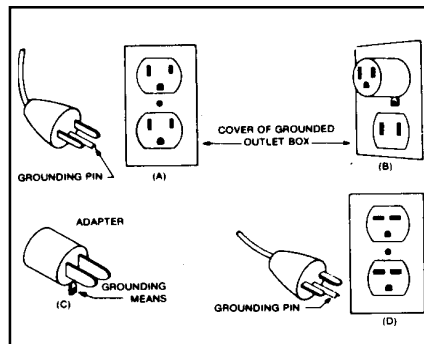

adapter should be used only until a properly grounded outlet can be installed by a qualified electrician. A temporary adapter which looks like the adapter illustrated in sketch (C), may be used to connect to a 2-pole receptacle as shown in Sketch (B). The green-colored rigid ear, lug, etc. extending from the adapter must be connected to a permanent ground, such as a properly grounded outlet box or a cold water pipe (metal).

SAFETY PRECAUTIONS

1. **KEEP GUARDS IN PLACE** and in working order.

2. **REMOVE ALL TOOLS FROM THE WORKAREA** before turning lathe on. Always place tools in storage area.

3. **KEEP WORKAREA CLEAN.** Cluttered areas and benches invite accidents.

4. **DON'T USE IN DANGEROUS ENVIRONMENT.** Use lathe indoors only. Don't use lathe in damp or wet locations, or expose to rain. Keep work area well lighted.

5. **DON'T FORCE LATHE.** It will do the job better and safer at the rate for which it was designed.

6. **USE RIGHT TOOL.** Don't force lathe or attachment for a job for which it was not designed.

7. **WEAR PROPER APPAREL.** Do not wear loose clothing, gloves, necktie, rings, bracelets, or other jewelry that might get caught in moving parts. Nonslip footwear is recommended. Wear protective hair covering to contain long hair.

8. **ALWAYS WEAR SAFETY GLASSES.** Everyday eyeglasses only have impact resistant lenses, they are NOT safety glasses. Also use face or dust mask if cutting operation is dusty.

9. **DON'T OVERREACH.** Keep proper footing and balance.

10. **MAINTAIN LATHE WITH CARE.** Keep cutters sharp and clean for best performance and to reduce the risk of injury to persons. Follow instructions for lubricating and changing accessories.

11. **DISCONNECT LATHE** before servicing, or when changing accessories, such as spacers, collets, cutters and the like.

12. **REDUCE THE RISK OF UNINTENTIONAL STARTING.** Make sure unit power switch is in the off position before plugging in.

13. USE RECOMMENDED ACCESSORIES. The use of improper accessories could result in risk of injury to persons as well as cause poor performance on disks or drums being machined. Consult the operator's manual for recommended accessories.

14. CHECK FOR DAMAGED PARTS. Before use of the lathe, a guard or other part that is damaged should be checked to determine that it will operate properly and perform its intended function. Check for alignment of moving parts, binding of moving parts, breakage of parts, mounting, and any other conditions that may affect its operation. A guard or other part that is damaged should be properly repaired or replaced.

15. DIRECTION OF FEED. Feed work into cutter against the direction of rotation of the cutter only.

16. NEVER STAND ON TOOL. Serious injury could result if tool is tipped or if the cutting tool is unintentionally contacted.

17. NEVER LEAVE LATHE RUNNING UNATTENDED. TURN POWER OFF. Don't leave lathe until it comes to a complete stop.

18. CLEAN CHIPS FROM LATHE. Chip accumulation can cover tips, preventing proper adjustment. Never use your fingers to remove chips from cutter tips. Use a brush to remove chip accumulations.

19. KEEP UNAUTHORIZED PERSONNEL AWAY from all equipment in shop. Alternative - disconnect all electrical cords from wall plug.

20. ADDITIONAL SAFETY PRECAUTIONS are noted throughout this manual.

21. USE PROPER EXTENSION CORD. Make sure your extension cord is in good condition. When using an extension cord, be sure to use one heavy enough to carry the current your lathe will require. An undersized cord will cause a drop in line voltage resulting in loss of power and overheating. See chart below for correct size to use depending on cord length and ampere rating. If in doubt use the next heavier cord. **NOTE:** the smaller the gage number the heavier the wire.

Total length of cord in feet	AWG
0 - 50ft	14
50 - 100ft	12
over 100ft *	
Not Recommended over 100 ft.	
Size figured for voltage of 115v @ 14amps	

1. This lathe was thoroughly tested before shipment to perform all operations for which it was designed.
2. Before operating your lathe, read and thoroughly familiarize yourself with the contents of this manual. Your JBC Dealer or Representative is available to acquaint you with the features of this lathe. Do not operate the lathe until you understand all of its functions.
3. Become familiar with the standard equipment supplied with your lathe. Review the adapter chart supplied and determine if optional adapters will be required for the type of passenger cars and light trucks that frequent your establishment.
4. For your convenience, when supplies and parts are required, John Bean has a serviceman caring for your area who carries parts for emergency requirements. Refer to the Parts Reference and order parts by their 'Part Number'.

This manual contains operating instructions, safety information, preventive maintenance instructions, and other information relating to the proper operation of John Bean Lathes.

Table of Contents	
Topics of Interest	Page
Check List _____	1
Safety Instructions _____	1
Preview _____	2
Specifications _____	3
Standard Equipment _____	3
Feeds and Speeds _____	4
Cutting Tools _____	5
Installation Instructions for 600 Series Lathes _____	5
Mounting Equipment on Base or Bench _____	6
How to Machine a Brake Drum _____	8
How to Machine a Disc Brake Rotor _____	11
Operating the Lathe _____	12
Preventive Maintenance _____	15
Warranty _____	17

SPECIFICATIONS

Capacity:

Drums 6" diameter, 6" wide face
Discs 6" to 20" Diameter, 2" thick

Spindle Speed 105 and 160 RPM

Feeds:

Power crossfeed: .001 - .010" per spindle revolution
Carriage: .005 & .0125 per spindle revolution

Motor:

1 HP, 115-230 Volt, 50/60Hz, 1Phase

Shipping Weight:

600 - 320 lbs.

Notice: Components of the 600 Series Lathes may change as requirements vary and these changes will be made, to increase the basic capacity of the equipment, without prior notice.

Notice: In the event the motor should be determined unserviceable, the motor should be replaced only with a unit purchased through JBC or a JBC certified representative.

Standard Equipment for the 600

Catalog Number	Description	Supplied with		
		600	601	610
90526	Floating Drum Attachment	1	1	
90194	Silencer - Lg. Passenger Car Rotor		1	1
90989	Silencer - Passenger Car Rotors		1	1
90196	Silencer - Sm Solid Rotor		1	1
90988	Silencer - Sm. Passenger Car Drums	1	1	
90198	Clip-on Silencer		1	1
90490	Cutter Kit, RH Cutter with 2 - 90847 Tips	1	1	
90519	Small Disc Collet Adapter	2	2	2
90520	Medium Disc Collet Adapter	1	1	1
90521	Large Disc Collet Adapter	1	1	1
90527	Hubless Rotor Adapter Set		1	
90528	Hubless Rotor Adapter Set			1
90547	Self-centering Arbor Nut	1	1	1
90554	Spacer, 1" Long	1	1	1
90578	Spanner Wrench	1	1	1
90556	Spacer, 2" Long	1	1	1
90644	Rotor-Truer with 90495 LH & 90494 RH Cutters and 90711 Spacer		1	1
90178	Chrysler Drum/Disc Collets	1	1	1
90642	Drum Cutter Tool	1	1	
90156	Collet, Chrysler - Special	2	2	2

FEEDS AND SPEEDS

1. Drum Machining - 600 is equipped with two feed speeds. **See Figure 1.**

A. Rough Cut - .0125" per spindle revolution.

B. Finish Cut - .005" per spindle revolution.

The above feed settings have been established after years of research and experience in conjunction with car manufacturers' recommendations. A finish cut produces an excellent surface for all types of or brake linings, hard or soft, woven or molded.

2. **Disc Machining** - Model 600 Lathes are equipped to machine disc brake rotors with a feed rate of .003" per spindle revolution.

This feed rate will produce the desired finish on rotors.

Normally, the finish of the rotor after machining will meet or exceed most car manufacturers' specifications. If you desire an even smoother finish, an approximate 30 second application for each side of the rotor with the 90646 Rotor Finisher (optional accessory) will provide a smooth non-directional finish. **See Figure 2.**

3. All Model 600 Lathes are equipped with a motor and pulleys to produce spindle speeds of 105 and 160 RPM, **See Figures 3 and 4.**

A. Most passenger car drums and rotors can be machined at the 160 RPM.

B. The 105 RPM is recommended for drums and rotors over 12" in diameter. Some drums and rotors which have hard spots can be satisfactorily machined at this speed.

C. To decrease or increase speed, the belt must be moved to the top largest diameter pulley for 105 RPM or to the top smallest for the 160 RPM.

D. With the motor turned off, pull the belt guard back, placing hand as shown in figure 4, until the upper pulley is exposed. Then lift the base of the motor and move the belt as described above.

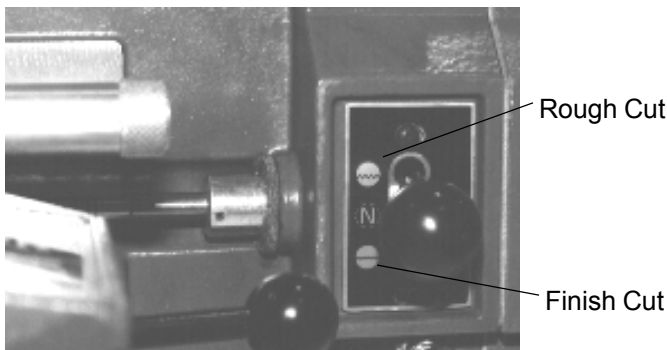



Figure 1



WARNING!!!

Turn motor off before attempting to move belt. Motor may accidentally engage resulting in serious personal injury.

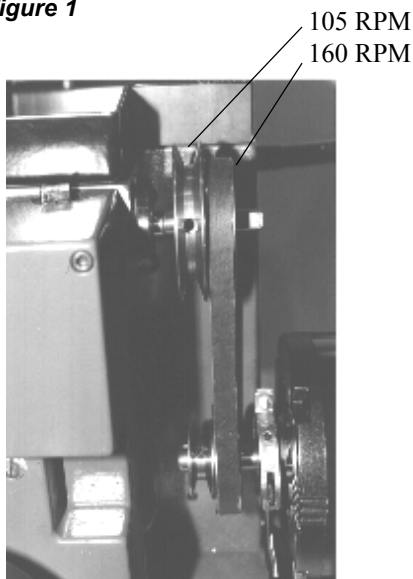

Figure 3



Figure 2

Move Belt Guard to Down Position

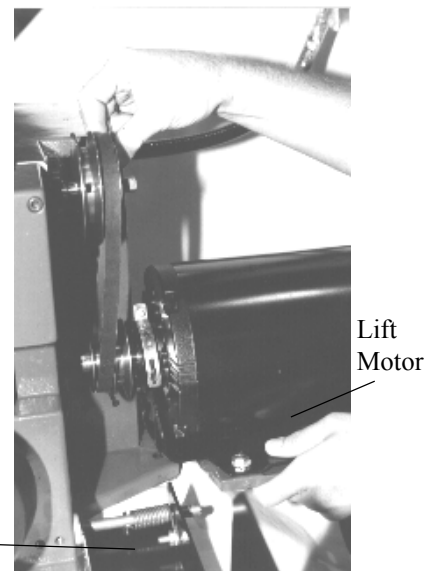
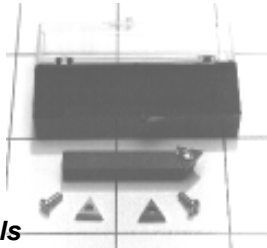

Figure 4

CUTTING TOOLS

Tool Holders, Cutter Shanks and Carbide Tips

1. JBC Lathes are designed to use cutter shanks with No. 90487 carbide tips with three cutting edges.



Cutting Tools

Cutters Supplied with 600

90490 Right Hand Cutter Kit with 2 extra
90487 Carbide Tips

90494 Right Hand Cutter with 90487 Carbide Tip

90495 Left Hand Cutter With 90487 Carbide Tip

2. IMPORTANT: Sharp cutting tips must be used at all times. A dull cutter will affect the finish of both drums and rotors.

3. Cutter shanks with coated carbide tips are available for heavy duty drum and disc machining. Order part number 91281 for a pack of ten.

4. Tip life is affected by speed, grade of carbide, cutter tip design and size. These are all based on mechanical considerations of the lathe - motor, speed, and gear ratios.

5. Check tightness of carbide tip in the cutting tool. Examine for breaks on the cutting edge. If the cutting edge is damaged, replace it promptly. Be sure no metal chips are under tip when changing tips.

Be sure to keep an adequate supply of replaceable carbide tips on hand at all times.

INSTALLATION INSTRUCTIONS

For 600 Brake Lathes

Electrical Requirements:

1. Refer to the name plate located on the back of the lathe. Be sure the power source is of sufficient voltage and amperage to operate the lathe. If in doubt, have a qualified electrician check. **See Figure 5.**

2. Domestic Lathes. An approved three-wire cord and a three-pronged plug is supplied with the lathe and the prong for grounding must not be removed. Change the receptacle in the wall socket if necessary to insure proper grounding.

If the use of an extension cord is necessary, use a heavy duty 3-wire cord containing a grounding prong and the proper receptacle to accept the plug on the lathe cord.



WARNING!!!

Lathe must be grounded whenever in use. Failure to do so may result in electrical shock and cause serious personal injury.

Brake Lathe

Model	600
Serial #	J81JM030
Volts 115	Amps 14
Hz 60/50	Phase 1



John Bean Company
Conway, AR. 72032

Figure 5

3. Should the electric power supply cord become damaged, repair or replace it immediately. Use only part number specified or equivalent.

4. If wiring the lathe to a permanent connection is desired, be sure the ground wire in the lathe cord is connected to a ground in an approved metal outlet box. The power source must be fused or have a circuit breaker large enough to handle the voltage and amperage as specified on the name plate.

Initial Cleaning/Lubrication

Clean all machined surfaces of factory-applied rust preventive. Apply a good lubricant (e.g. WD40 or CRC) to the dovetail ways (housing & carriage), cross slide and rotor truer. **See Figure 10.**

MOUNTING EQUIPMENT

On Base or Bench

1. The Base is designed for one lathe. Follow assembly instructions supplied with each.
2. Mounting hardware, nuts, bolts, accessory hooks, etc. are supplied with the bench. **See Figure 6.**
3. A rubber pad is supplied with the 674 Base, and must be used between the lathe and the base.

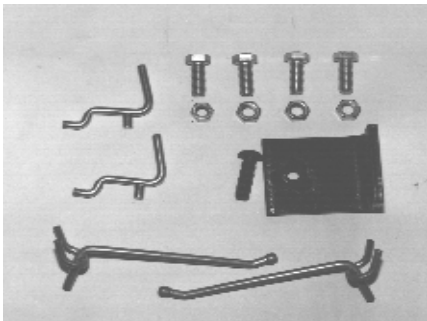

Figure 6

4. Be sure the mounting bolts are tightened securely to eliminate any possibility of vibration. If the lathe is not mounted securely, it may cause the lathe to operate improperly.
5. Provisions for storing adapters and accessories are incorporated with the Base. **See Figure 7.** Accessory hooks are supplied for cones, spacers, and collets. A shelf is provided for larger items.
6. Adapters and accessories should be stored on the accessory hooks provided underneath the top of the base, or on the sign board.

Base with Lathe,
Sign and Accessories

WARNING!!!
Keep all loose equipment properly stored and away from the area of the revolving hand wheel. See Figure 9.



Figure 9

Drum Prevents hand wheel from turning, causing damage to gear train.

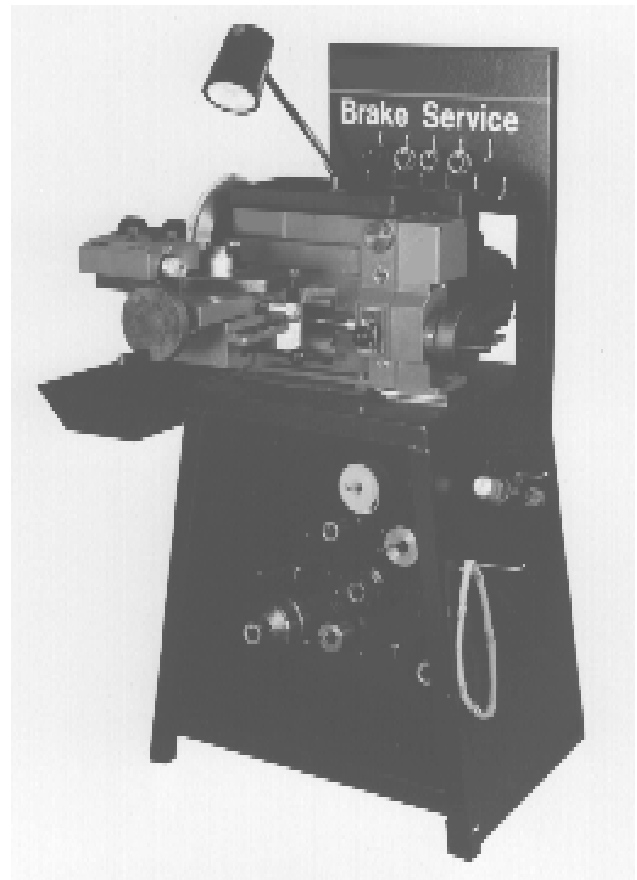

Figure 7

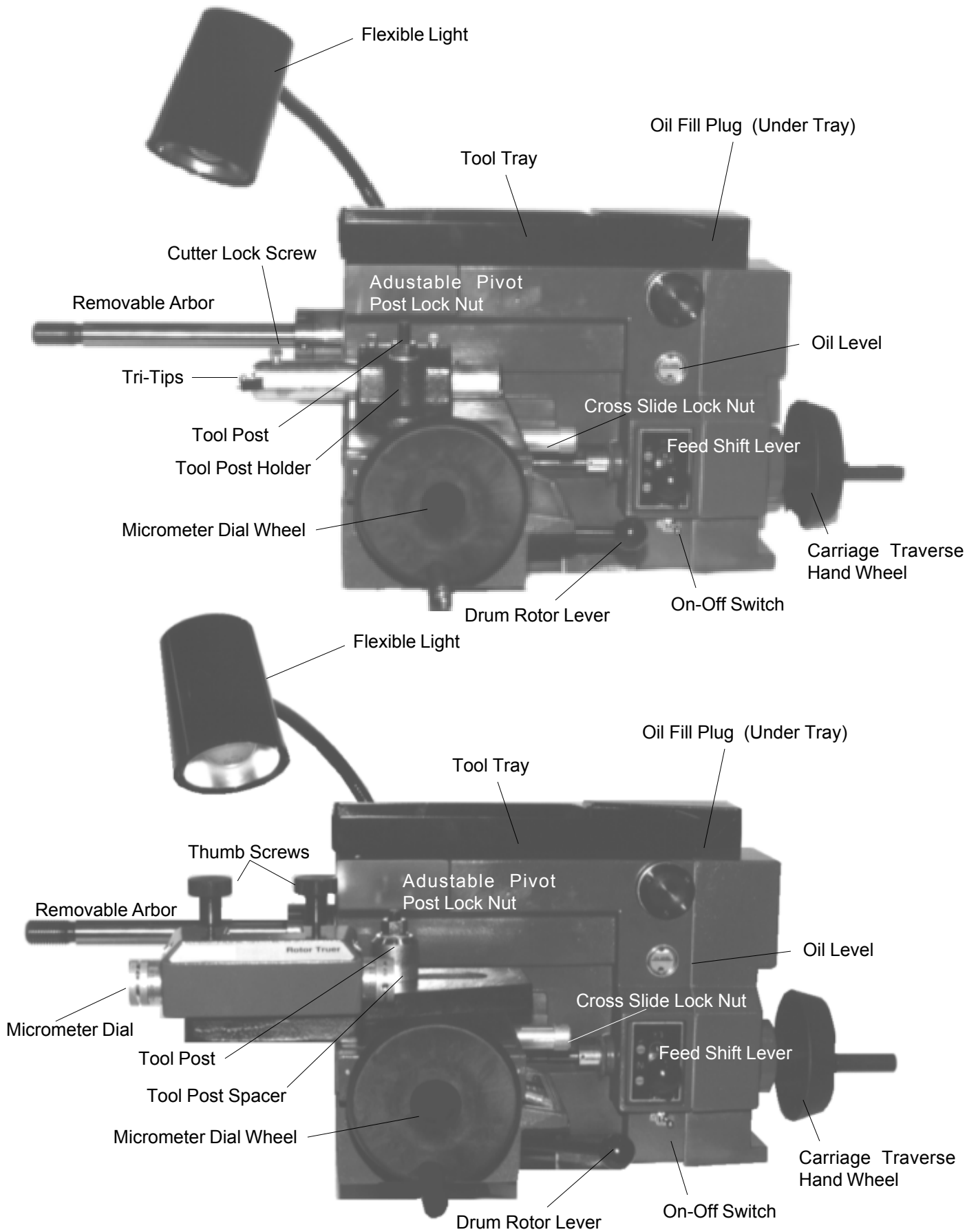

Figure 10

HOW TO MACHINE A BRAKE DRUM

Model 600

See Figure 10.

After the following instructions are read and understood, obtain a scrap brake drum for practice. Select the proper adapters for mounting on a spindle. Mounting is one of the most important functions of the machining operation, since it affects accuracy and finish.

Practice setting cutter for machining drums. Learn all the functions thoroughly to insure proper operation.

Machining Limitations - Drums

Drums produced recently have the maximum drum diameter value cast into the outer surface. The proper procedure for determining whether to resurface drums or discard them is listed below:

- A.** Check to see if the brake drum has a maximum size cast into it. If not, refer to the current JBC Drum and Rotor Specifications Book.
- B.** Measure the drum with the optional JBC 90240 Drum micrometer (90239 - Metric) and, if it is smaller than the maximum allowable size, it can be machined.
- C.** After machining, check size again with the Drum Micrometer and discard if it is beyond the maximum limits.

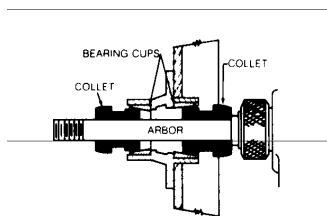

Figure 11
Use of collets to mount tapered roller bearings equipped brake drums.

Mounting Brake Drums

1. Hub type Drums.

On a 600 Lathe, proceed as follows:

A. Clean excess grease from bearing races of drum. Inspect bearing races for damage and replace if necessary.

B. Select collets to fit in bearing races, by referring to the current Drum and Rotor Specs. book.

C. Install collet for inner bearing race on arbor. See Figure 11. Mount the drum (to be Machined), the collet for outer bearing race, and necessary spacers to fill arbor past mounting surface. Install arbor nut and tighten by hand. This will center the drum on the collets. Using 90578 Spanner Wrench, tighten arbor nut snugly. If drum touches housing, place a spacer on arbor between inner collet and arbor shoulder.

D. IMPORTANT: Do not overtighten arbor nut when mounting drums or rotors on the spindle. Usually the pressure of one hand with the Spanner Wrench engaged in the arbor nut is sufficient to tighten. See Figure 14. If spacers and adapters are not clean and free of nicks, burrs or foreign matter when the arbor is tightened, it could introduce spindle runout. This can be detected by observing the end of spindle when the arbor is revolving. If this occurs, check spacers and adapters for nicks, etc., to be sure they are smooth and clean and that the arbor nut is properly tightened.

E. Wrap a 90988 silencer around the drum (snug, but not too tight). See Figure 14. The rubber silencer deadens vibration of the drum while Machining. A brake drum is like a bell and

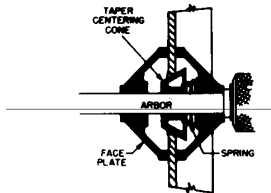

Figure 12
Use 90526 floating drum attachment to mount floating hubless rear drums.

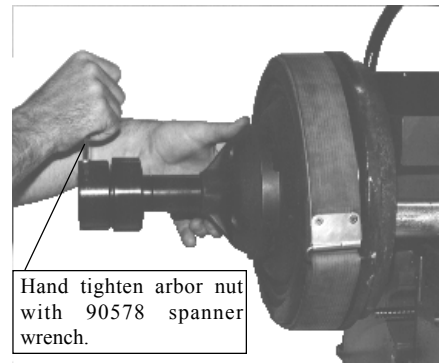

Figure 14

when it is Machined without the silencer band, vibration is created by the cutter tip removing metal, resulting in a poor finish.

For wider drums or large finned drums, the wider, optional 90983 Deluxe Silencer band is recommended. See Figure 13.

2. Mounting Hubless Brake Drums.

A. When machining rear hubless drums, use the 90526 Floating Drum Attachment (90559 or 90560 Truck Face Plate Set if truck drums are to be machined), select the proper cone to fit the center hole in the drum. Follow the illustration as shown in Figures 12 & 15.

B. Clean the inner face of the drum with a wire brush.

C. Place one face plate over arbor. Install spring and centering cone.



Figure 13
Dampen vibrations during the Machining operation. Excessive tightness of silencer on drums may result in minor chatter.

D. Place drum over the centering cone and follow with the other face plate and necessary spacers to fill arbor past mounting surface. Install arbor nut and tighten by hand. This will center the drum between the face plates.

E. Tighten arbor nut snugly with spanner wrench. If drum touches housing, place a spacer on arbor between inner face plate and arbor shoulder.

NOTE: If you experience hard spots when Machining front and rear drums, turn motor off, slow the speed and finish the cut. If the finish is objectionable, discard the drum.

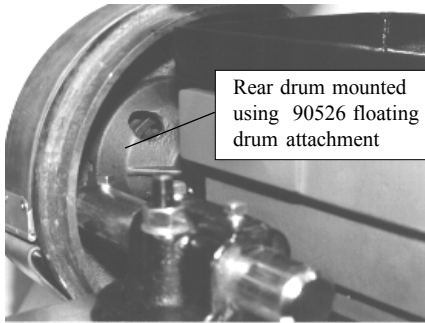

Figure 15
Operating Lathe

1. The Model 600 Combination Drum and Disc Lathe is equipped with a control lever on the carriage.

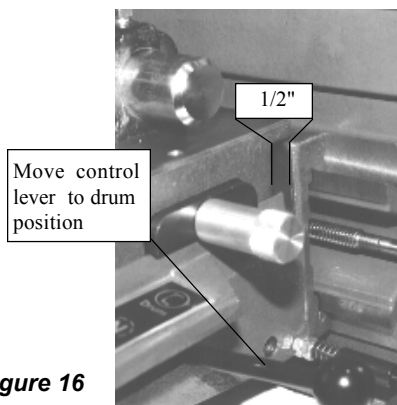

Figure 16

This control lever must be in the drum position to machine a brake drum. **See Figure 16.**

2. Depending on width of drum, advance carriage assembly toward the drum by turning carriage traverse hand wheel clockwise, until left side of carriage is approximately one-half inch beyond the end of lathe housing.

3. Move cross slide to its innermost position and then back off by turning dial wheel five turns (about 1/2") counterclockwise. Loosen nut and adjust tool post holder, tool bar, and cutter assembly to approximate drum diameter. Tighten nut and leave feed shift lever in neutral (N) position. **See Figure 17.**

4. Loosen two square head set screws on tool post holder and move cutter and tool bar into brake drum until it

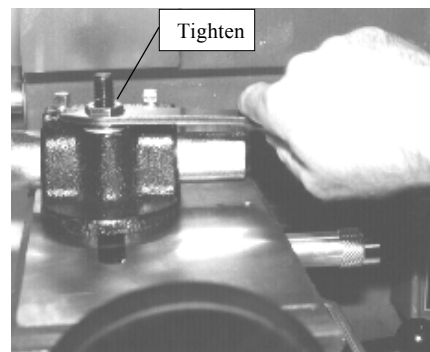

Figure 17

touches back of drum. While tightening set screws, rock tool bar clockwise and counterclockwise until set screws tighten on flat surfaces. Cutter tip should extend from tool bar no more than 3/4" when turning a typical brake drum. Some small drums may

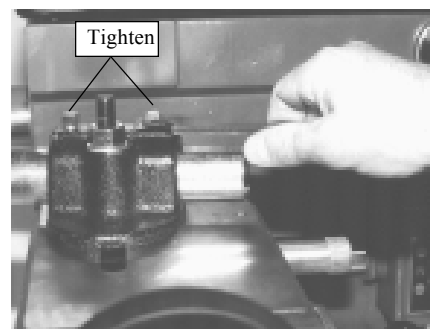

Figure 18

require less cutter extension. **See Figure 18.**

5. Turn lathe on and advance carriage by turning traverse hand wheel until cutter is at the extreme back of drum. Advance cutter into braking surface to be machined by turning micrometer dial wheel counterclockwise. Continue turning dial wheel until desired depth of cut is obtained. **NOTE:** Micrometer dial wheel reading indicates the amount of metal removed from diameter of drum (not radius).

6. Tighten adjusting knob on side of carriage. Engage feed lever in either rough or finish cut, depending on the condition of the drum surface to be machined.

NOTE: When machining a barrel shaped or worn drum, the outer edge (open end) of drum usually has a smaller diameter than the center section where the brake shoe exerts the most wear. The smaller diameter area (outer edge) must be machined first before making the finish cut. **See Figure 19.**

Some drums may have a deep groove or grooves (usually .020" or less) that can be Machined in one pass. When this condition exists, move cutter to bottom of deepest groove and note micrometer dial reading. Turn dial wheel to remove cutter from groove

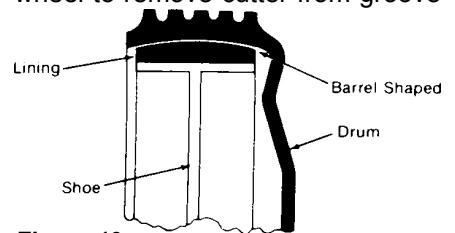

Figure 19

and move cutter to back of drum. Turn dial wheel to previous measurement plus .002 or .003 inches and proceed to machine drum as described below. **See Figure 20.**

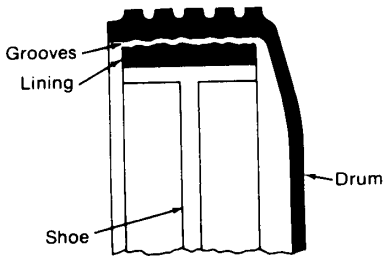

Figure 20

7. When the machining is completed, disengage feed lever from finish cut to neutral (N). **See Figure 21.**

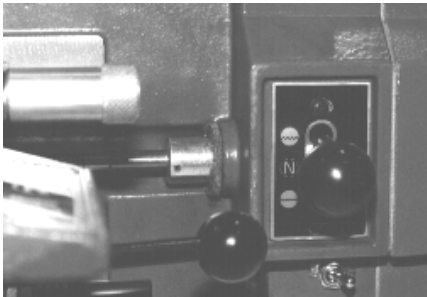

Figure 21

8. The lathe is equipped with an automatic shut-off rod. It is preset at the factory to turn lathe off when the carriage reaches its maximum travel to the right.

CAUTION!!
DO NOT REMOVE THE SHUT-OFF ROD

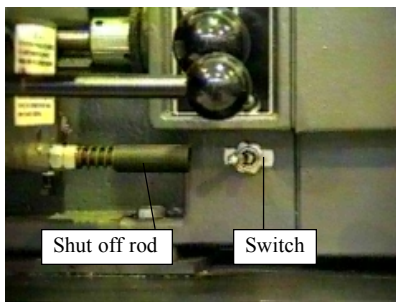

Figure 22

A safety factor has also been incorporated with an undercut on the carriage feed screw. This feature prevents any damage to the lathe in case of an electrical switch malfunction. **See Figure 22.**

If the switch fails, the feed nut will drop into the undercut and the carriage movement stops. To re-engage the feed nut on the threads of the feed screw, turn off lathe, apply slight pressure on the right side of the carriage while turning hand wheel clockwise. Care must be taken not to crosstread the feed nut. If hand wheel turns hard, back off and start over again.

9. Prepare to remove the drum by turning the carriage traverse hand wheel counterclockwise to clear cutter from the drum and silencer band. Follow same procedure for front drums.

10. To remove a front drum from the arbor, loosen the arbor nut one turn and place the handle end of the spanner between the hub of the drum and the collet in the outer bearing race. Push the top of the wrench down toward the drum to free the collet from the bearing race. A slight hand tap on the wrench may be necessary. **See Figure 23.**

After the collet has been loosened, hold the drum with one hand and

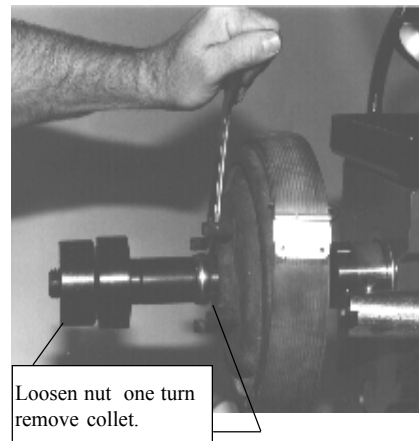

Figure 23

remove the arbor nut, spacers, collet, and the drum. Remove the remaining collet on the arbor and remove any foreign matter before mounting the next drum. Most rear drums are mounted with the 90526 floating drum

attachment, thus require no special demount instructions, other than to be careful not to allow drum to drop on the spindle when demounting.

11. If the next operation is to machine a rotor on a 600 lathe, proceed to page 11.

Adjusting Belt Tension

The Lathe is supplied with a spring loaded motor mounting that establishes the correct belt tension. See Figure 23A. The tension can be adjusted to obtain a quiet running motor as follows:

A. Turn wing nut counter-clockwise to increase belt tension.

B. Turn clockwise to decrease belt tension.

Normally, tension adjustment is only required when machining a large drum or when making an excessively heavy cut. **See Figure 23A**

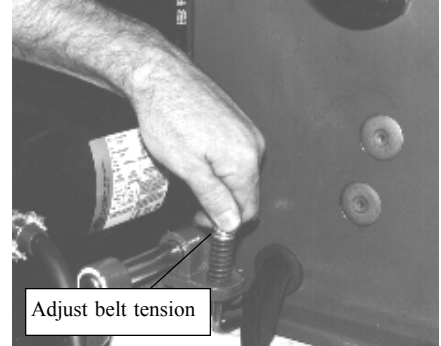

Figure 23A

HOW TO MACHINE A DISC BRAKE ROTOR

Model 600 Series

After the following instructions are read and understood, obtain a scrap rotor for practice. Select the proper adapters for mounting on spindle. Mounting is one of the most important functions of the machining operation, as it affects accuracy and finish.

Practice setting cutters for machining rotors. Learn all the function thoroughly to insure proper operation.

Machining Limitations - Rotors

Since 1971, rotors have the minimum thickness values cast into the outer surface.

The proper procedure for determining whether to resurface rotors or discard them is listed below:

A. Using a micrometer or some other micrometer suitable for measuring the thickness of the rotor to be machined, check the rotor thickness at four points (90 degrees apart) about 1" from the outer diameter.

B. If the thickness at any of the four points is less than the minimum established by car manufacturers as shown on the rotor or in the current Brake Specifications Book, replace the rotor.

C. The rotor may be resurfaced if scored or it has a small amount of runout, provided it is within the minimum thickness requirement.

D. After the rotor is machined, mea-

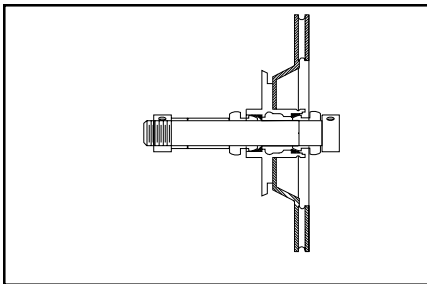

Figure 25 Use collets in bearing race as illustrated, add necessary spacers

sure the thickness again, and, if it is not within the allowable minimum limits, discard it.

NOTE: This check requires a measurement in only one spot if both braking surfaces cleaned up 100%, because the turning operation assures almost absolute parallelism.

Mounting Brake Rotors

1. Hub Type Rotors

On a 600 Series lathe, proceed as follows:

A. Clean excess grease from bearing races of rotor. Inspect bearing races for damage and replace if necessary.

B. Select collets to fit in bearing races. Refer to current Drum and Rotor Specs. book.

C. Install collet for inner bearing race on arbor. **See Figure 25.** Then mount the rotor, collet for outer bearing race, and necessary spacers to fill arbor past mounting surface. Install arbor nut and tighten by hand. This will center the rotor on the collets. Using 91286 Spanner Wrench, tighten arbor nut snugly. If rotor touches housing, place a spacer on arbor between inner collet and arbor shoulder.

2. Mounting Hubless Rotors.

A. Locate 90527 Hubless Rotor Adapter Set and proper cone to fit rotor to be machined.

B. Install one face plate over arbor, then follow with a spring and centering cone.

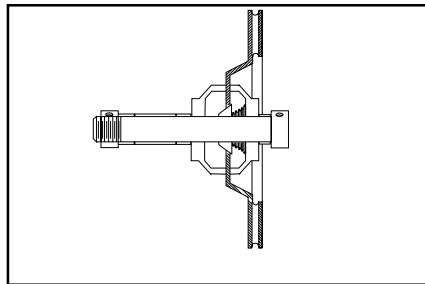

Figure 26 An accurate way to machine hubless rotors. Follow instructions supplied with 90527.

C. Place rotor over arbor and centering cone, then install second face plate over arbor and up against rotor.

D. Add necessary spacers to fill arbor past mounting surface. Install arbor nut and tighten by hand. This will center the rotor to the face plates. Use 90578 Spanner Wrench to tighten arbor nut snugly. If rotor touches housing, place a spacer on arbor between the inner face plate and arbor shoulder.

E. IMPORTANT: Do not overtighten arbor nut when mounting rotors on the spindle. Usually the pressure of one hand with the spanner wrench engaged in the arbor nut is sufficient to tighten. **See Figure 14.** If spacers and adapters are not clean and free of nicks and burrs or foreign matter when the arbor is tightened, it could introduce spindle runout. This can be detected by observing the end of the spindle when the arbor is revolving. If this occurs, check spacers and adapters for nicks, etc., to be sure they are smooth and clean and that the arbor nut is properly tightened.

3. Install Rotor Silencer.

Select silencer that is appropriate for rotor being machined, and install around outer edge of rotor. There are four (4) sizes of band type silencers, plus a clip-on silencer. One of them will be appropriate for the rotor being machined. **See Figure 27.**



Figure 27 90989 Rotor Silencer band.

Operating Lathe

1. Align the carriage pointer with the pointer on the lathe housing by turning the carriage traverse hand wheel. Control lever must be in DRUM position to move carriage. It is very important to view this alignment when you are directly in front of the lathe. If you are off to the side, the pointers may appear aligned, when in actuality, they are not. **See Figure 28.**

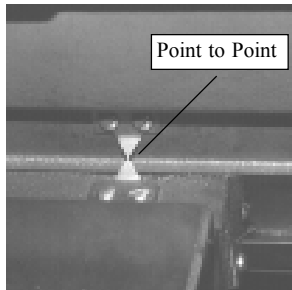

Figure 28 Point to point alignment

2. After pointers are aligned, save setup time by turning on the lathe and slowly pulling the control lever on the right side of the carriage to the rotor position.

This is the farthest movement toward operator. **See Figure 29.** The physical shape of the drive shaft and its mating driven shaft is a hexagon, just like a socket wrench and the head of a bolt.



Figure 29 -Pull lever to rotor position as shown

By carefully aligning the pointers (Step 1), you insure the proper alignment of the two hex parts.

If control lever moves freely to rotor position, alignment is correct. If it does not, then examine the pointers for proper alignment. Push the control lever to the neutral (N) position and turn off the lathe. **See Figure 30.**

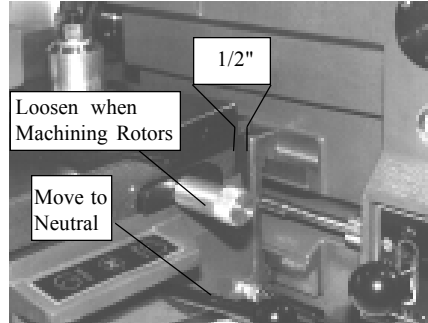

Figure 30

3. If drum machining was the last operation performed, remove the tool post nut, washer, and the tool bar assembly. Always loosen cross slide adjusting knob when preparing to machine disc brake rotors. **See Figure 30.**

4. Be sure the arbor and adapters are absolutely clean. A small chip, nick, or burr on the surfaces where spacers and adapters come together might cause the rotor to be machined inaccurately and create improper operation when the rotor is reinstalled on the vehicle.

Cleanliness is of the utmost importance. **See Figure 31.**

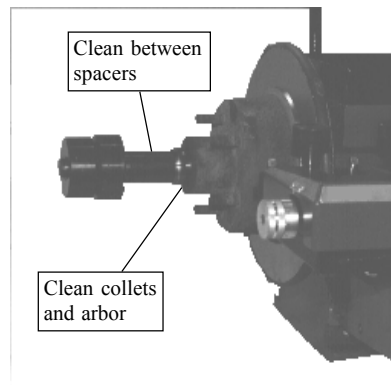

Figure 31

5. Mount the rotor on the arbor using the required adapters (collets, optional 90527 Hubless Rotor Attachment, or other Special Adapters).

6. Advance cross slide to within approximately 1/2" of its extreme inward position. **See Figure 30.**

CAUTION!!!

Before placing the rotor-truer on the adjustable pivot post, it is extremely important that all chips, dirt, and any foreign matter be removed from the top of the cross slide and the bottom surface of the rotor-truer plate. Because of the very large contact area between the rotor-truer plate and the cross slide, any small chips or pieces of dirt measuring only a few thousandths of an inch can cause the rotor to be machined improperly. If chips are present, you may notice that extra effort is required to turn the micrometer dial wheel. **See Fig. 30.**

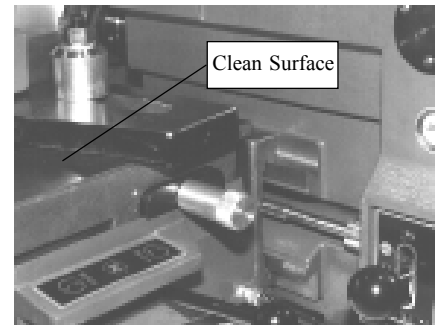

Figure 32

7. **IMPORTANT:** In all cases when machining rotors, be sure the adjusting knob that locks the cross slide is always loose. If tightened, it will create unnecessary wear and strain on the drive train. **See Figure 33.**

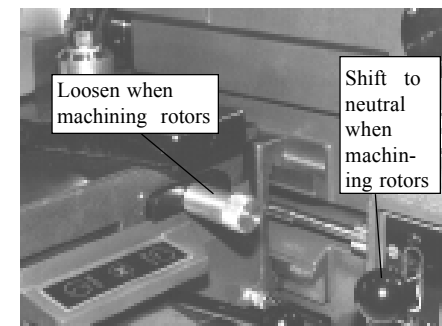

Figure 33

IMPORTANT:

Whenever machining a rotor always be sure the feed shift lever that controls the drum feed is in the neutral (N) position.

8. Now that the Rotor-Truer and cross slide surfaces have been properly cleaned, place the Rotor-Truer on the cross slide over the adjustable pivot post. Install a spacer, washer and nut. Hand tighten. See Figure 34.

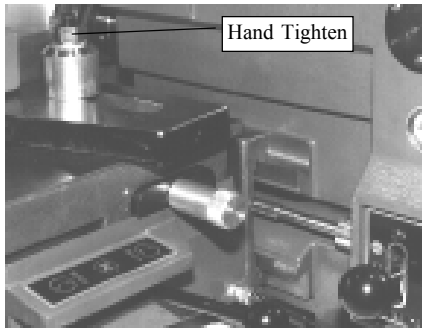

Figure 34

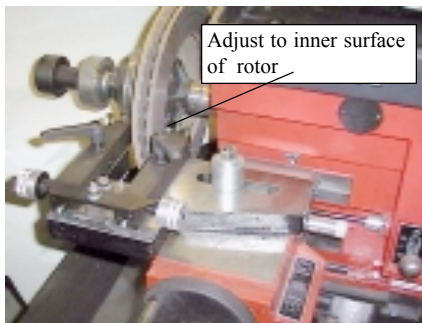

Figure 35

Adjust the cutting tips are approximately opposite each other and then tighten the nut with the spanner wrench, locking the rotor-truer in the operating position. See Figure 35.

NOTE: Some rotors have a swept area on more one side than the other, which necessitates adjustment of the cutters to insure both surfaces are machined complete at the same time.

NOTE: The T-slot feature, with its adjustable pivot post, allows you to machine rotors of all sizes with the cross slide dovetail ways in full contact with carriage. This insures maxi-

mum rigidity of the lathe, while machining either drums or rotors. See Figures 36 and 37.

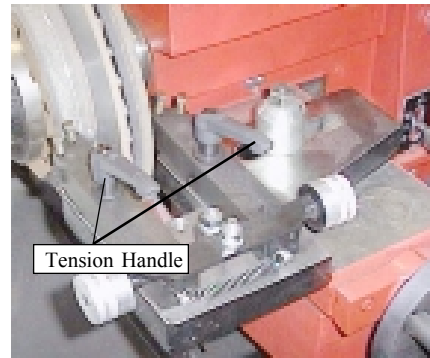

Figure 36

9. Arbor and feed rate can be selected to provide optimum cut. See page 4 for selecting the proper feed rate. A slow rate is also suggested for large rotors, while the faster rate is selected for smaller rotors.

10. Turn lathe on. If the rotor to be machined is rough and scored, with grooves no deeper than .010", move the cross slide until the cutter tip is opposite the deepest groove. Turn the knurled micrometer knob on the rotor truer until the cutter tip touches the bottom of the groove. Now turn the micrometer dial (next to the knurled knob) to zero. See Figure 37.

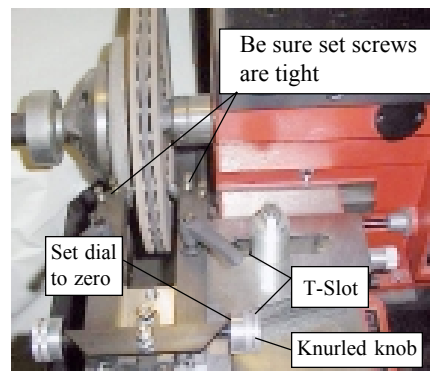

Figure 37 Groove simulated here.

IMPORTANT:

Be careful not to move the knurled knob which moves the cutter. Turn the knurled knob in until the cutter is clear of the rotor. Repeat this operation on the other side, if scored. In many instances, the other side may be perfectly flat and a normal cut can be taken.

11. With the lathe still running, advance the cross slide until these cutters reach the innermost portion of the braking surface. Turn the knurled knobs in the direction of the arrow with micrometer dial wheels past zero to .003 or .004" to clean up the rotor. See Figure 36.

12. Tighten the tension handles on top of the rotor truer to hold tool bars in proper position. See Figure 36. Engage the feed by pulling the control lever on the carriage slowly to the rotor position. The cutters will move across the face of the rotor, machining both sides simultaneously. On severely scored rotors, it may be necessary to make more than one cut. If so, repeat step 11.

NOTE: It is not necessary to loosen the tension handles in order to increase depth of cut.

13. Normally the finish of the rotor after machining will meet or exceed most car manufacturers' specifications. If a smoother finish is desired, an application with the 90646 Rotor Finisher on each side of the rotor for a 30 second duration will provide a smooth, non-directional finish.

14. Carbide tip cutters last longer providing more cuts per tip when the lathe is operated at low speed.

15. When machining is complete, move the control lever on the side of the carriage to the neutral position.

16. Prepare to remove the rotor by turning the micrometer dial wheel counter-clockwise until the cutters clear the rotor and silencers. See Figure 38.

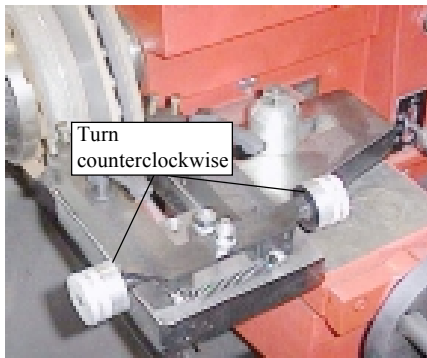

Figure 38

17. To remove the rotor from the arbor, loosen the arbor one turn and place the spanner wrench between the rotor and the collet in the outer bearing race. Push the top of the wrench toward the rotor, a slight hand tap on the wrench may be necessary to free the collet from the bearing race. **See Figure 39.**

After the collet has been loosened hold the rotor with one hand and remove the arbor nut, spacers, collet and the rotor.

Remove the remaining collet on the arbor and remove any grease or chips before mounting the next rotor or drum. Many rotors are mounted with the 90527 Hubless Rotor Attachment, thus requiring no special demount instructions, other than to be careful not to allow the rotor to drop on the spindle when demounting.

18. An important feature of this lathe is the control lever on the carriage. When in the neutral (N) position, the carriage is automatically locked in that position and conversely, when the control lever is moved out of the neutral position and into drum position, the carriage is unlocked for movement during the drum machining operation. **See Figure 40.**

19. If another rotor is to be machined, repeat the operation described above. If the next operation is to machine a drum, move the control lever to the drum position, remove the Rotor Truer and install the tool bar assembly. Then proceed with steps shown in "How to Machine a Brake Drum" on page 8.

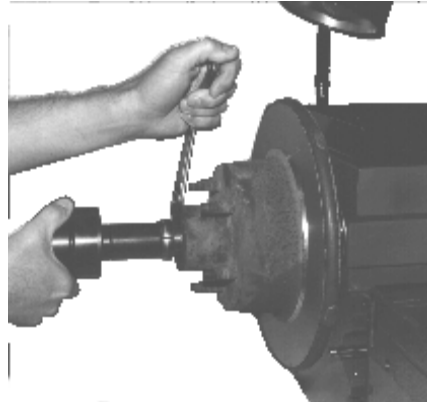

Figure 39

20. In the case where the cross slide is allowed to run until it begins to 'Free Wheel'. Reverse the direction of the cross slide by placing the shift lever in neutral and turning the dial wheel until the cranking handle is at the 6 o'clock position. Using the heel of the hand, firmly bump the end of the cross slide and, at the same time, start turning the dial wheel. If, for any reason, the feed nut and feed screw tends to bind up during this re-engagement action, back up and start over.

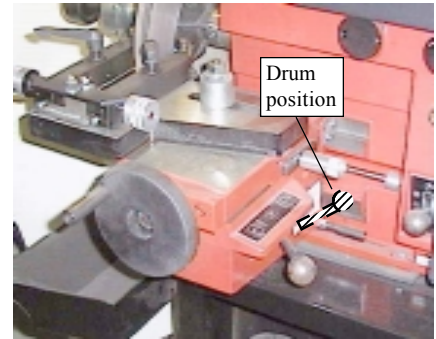



Figure 40



WARNING:

Do not force re-engagement because it may result in damage to the feed nut.

PREVENTIVE MAINTENANCE

1. The satisfactory performance of precision brake service equipment is directly proportionate to the care given each item by the operator.

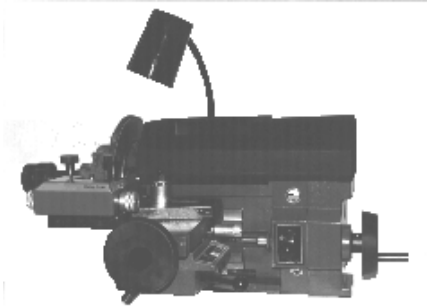

Figure 50

2. As part of the maintenance procedure, we remind the operator not to operate the lathe unless oil in the gear case (viewed through the oil sight tube) is up to the center mark when lathe is not running. If below center, add SAE 90 wt. oil to bring oil up to the center mark.

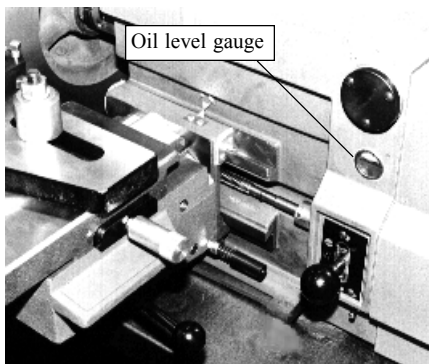

Figure 51

IMPORTANT: Do not over fill. See Figure 51.

3. When first operating the lathe, a small amount of oil leakage at the breather is normal. The reason for this is that pressure builds up in the oil cavity. This is normal to the operation of the lathe. Add oil when necessary. See Fig 52.



Figure 52

4. Always keep the lathe as clean as possible. A 2" paint brush is an excellent tool to assist the operator with cleanliness. Brush chips off of dovetail ways, carriage, cross slide, tool bar and holder, rotor truer, and cutters.

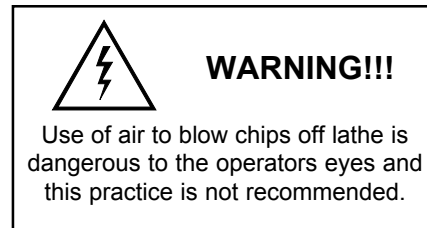

5. An occasional spray of lubricant (CRC or WD40) on the feed screw and nut is recommended. See Figure 53.

6. It is important to keep the arbor clean and lightly lubricated to permit adapters and collets to slide on and off easily. See Figure 53.

7. After using adapters, collets or cones, a few seconds spent to wipe off dirt, chips and grease is recommended. This helps maintain accuracy at all times. It is also recommended that the slots in collets be cleaned periodically. This can be accomplished easily with a length of soft twine by running it back and forth in the slots. Wipe off dirt as it is removed from the slots in the collets.

See Figure 54.

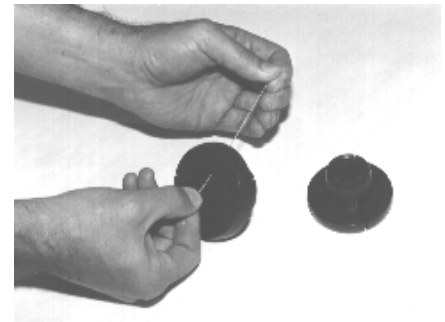

Figure 54

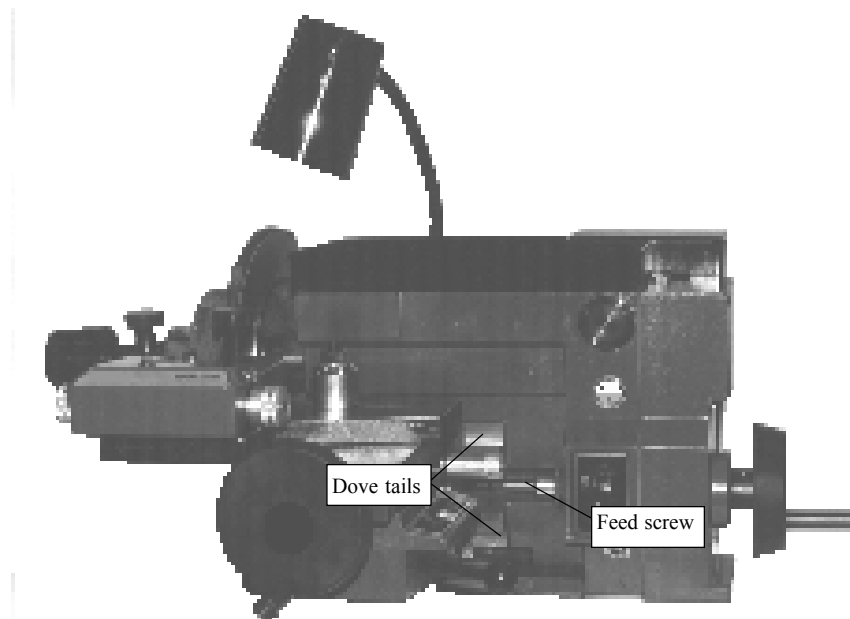

Figure 53

8. The rotor truer must be kept clean. A periodic spray of lubricant directed under the cover casting is recommended. This will keep the tool bar lubricated and operating freely when turning the micrometer feed dial knobs. **See Figure 53.**

9. After each three months of operation, lubrication with chassis grease through grease fitting at arbor end (on the back side of the housing) is recommended. **See Figure 53.**

10. Check the "v" belt for alignment and wear; check tightness of the pulleys periodically. Be sure the belt is vertical, pulley set screws are tight and motor is properly secured to motor mounting base.

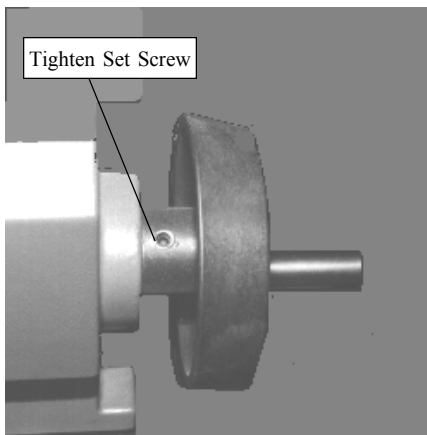

Figure 55

11. Periodically check the retaining screw on the carriage traverse hand wheel for looseness. If found to be loose, tighten securely. Spray the handles of hand wheels with lubricants so they turn freely and are easy to operate. **See Figure 55.**

12. Check gib wiper on carriage to make sure that chips are being removed from ways as carriage moves back to prevent any undue wear on the surface of the ways. Replace the felt wipers, if worn. **See Figure 56.**

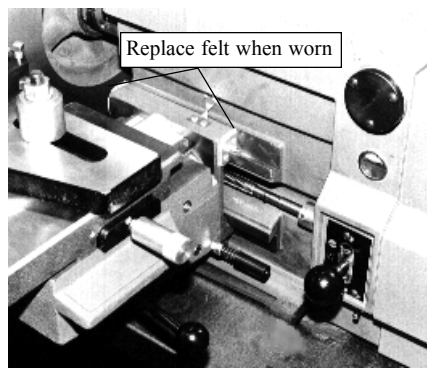

Figure 56

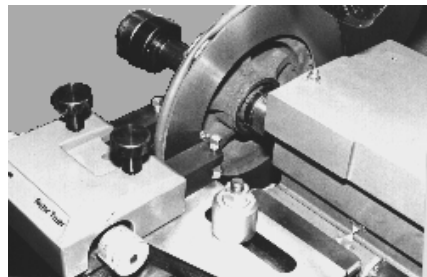

Figure 57

13. Check the electric cords for breaks or cuts that may cause short circuiting. Replace defective cords promptly.

14. Check the silencers periodically for possible damage. **See Figure 57.**

15. There is a possibility, after considerable use, that a clicking noise may be heard when Machining a rotor. This noise is caused by the loss of elasticity in the rubber silencer and, as the rotor revolves, the metal tubes move away from the rotor and then snap back. It is recommended that the 90195 silencer band be replaced if this noise occurs.

16. Periodic adjustment of the cross slide and carriage gibs may be necessary. Slight tightening of the lock nut will provide the desired adjustment of the cross slide gib. If necessary, make the same adjustment on the

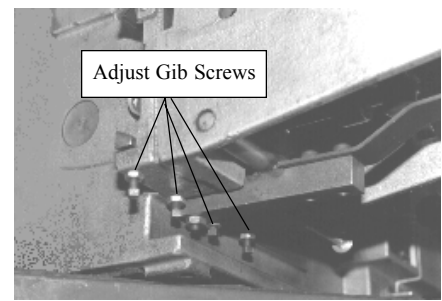

Figure 59

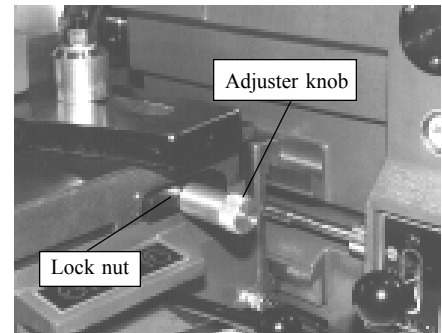

Figure 60

carriage gib screws located under the carriage. Test tightness by turning the dial wheel and the hand wheel. If correct, a slight drag should be felt. **See Figures 59 and 60.**

STANDARD FACTORY WARRANTY

JOHN BEAN 600 SERIES BRAKE LATHES: John Bean Company warrants each new Brake Lathe to be free from defects in material and workmanship for a period of 12 months from the date of original equipment installation to the original equipment owner under normal use and service. The labor and service call charges to correct such defects is covered by this warranty for 90 days. Brake Lathe accessory items are warranted to be free from defects in material and workmanship for a period of 90 days including labor and Service call charges. **THE FOREGOING WARRANTY IS IN LIEU OF ALL OTHER WARRANTIES, EXPRESSED OR IMPLIED, INCLUDING THOSE OF MERCHANTABILITY OR FITNESS FOR ANY PURPOSE.**

John Bean will not be responsible for claims arising on any unit which (1) has been subject to misuse through negligence or accident (in installation or operation), (2) shall have been repaired altered or serviced in any manner by anyone other than John Bean Company or its authorized representative, or (3) shall have been operated in a manner other than as specified by John Bean Company so as, in our judgment, to affect its operation adversely, when the claim is due to one of the above mentioned causes.

Any cause of action for breach of the foregoing warranty must be brought within one year from the date the alleged breach was discovered or would have been discovered, whichever occurs first.

John Bean's liability for our products shall be limited to, and the customer's remedies are limited to repairing or replacing parts found by us to be defective, or at our option, to refunding the purchase price of such products or parts. At our request, Buyer will send, at Buyers expense, any allegedly defective parts to the plant which manufactured them.

DISCLAIMER OF CONSEQUENTIAL DAMAGES

Seller shall not be liable for consequential damages arising out of or in connection with its products. Consequential damages shall include, without limitation, loss of use, income, or profit, loss sustained as the result of injury (including death) to any person, or loss of or damage to property (including property handled, processed or tested by our products). NOTE: The equipment registration card attached to each serialized item must be completed and returned to the factory for warranty to be valid.

John Bean Company

**Exchange Avenue
Conway, Arkansas 72032**



John
BEAN
Company

USA

John Bean Company
309 Exchange Avenue
Conway, Arkansas 72032
Tel.: (800) 362-8326 or (501) 450-1500
Fax: (501) 450-1585

IRELAND

Formguide Services Ltd.
T/a John Bean Company
Sitecast Industrial Estate
Little Island, Cork
Tel: (353) 21-354477
Fax: (353) 21-354488

GERMANY

John Bean Auto Service Gerate
Division to Sun Electric Deutschland GmbH
Gewerbepark Sinn
D-35764 Sinn Herborner Str. 7-9
Tel: (49) 2772-9404-0
Fax: (49) 2772-9404-23

FRANCE

John Bean Company
Z.I. Du Haut Galy - Galy 8
93623 Aulnay S/S Bois
Tel: (33) 1-4865-3828
Fax: (33) 1-4865-7331

CANADA

John Bean Company
6500 Millcreek Drive
Mississauga, Ontario
Canada L5N 2W6
Tel: (905) 814-0114
Fax: (905) 814-0110

LATIN AMERICA

Rua Apinages
1268 cj. 605B
Perdizes-Sao Paulo-S.P.
Cep: 05017-0000
Brazil
Tel: (55) 11-871-0713
Fax: (55) 11-871-0713

Notice: The information contained in this document is subject to change without notice. **John Bean Company** makes no warranty with regard to this material. **John Bean Company** shall not be liable for errors contained herein or for incidental consequential damages in connection with furnishings, performance, or use of this material.

This document contains proprietary information which is protected by copyright and patents. All rights are reserved. No part of this document may be photocopied, reproduced, or translated without prior written consent of **John Bean Company**.

John
BEAN is a registered trademark of the John Bean Company and Snap-on Corporation.