

User's Manual

WB250 and WB260A

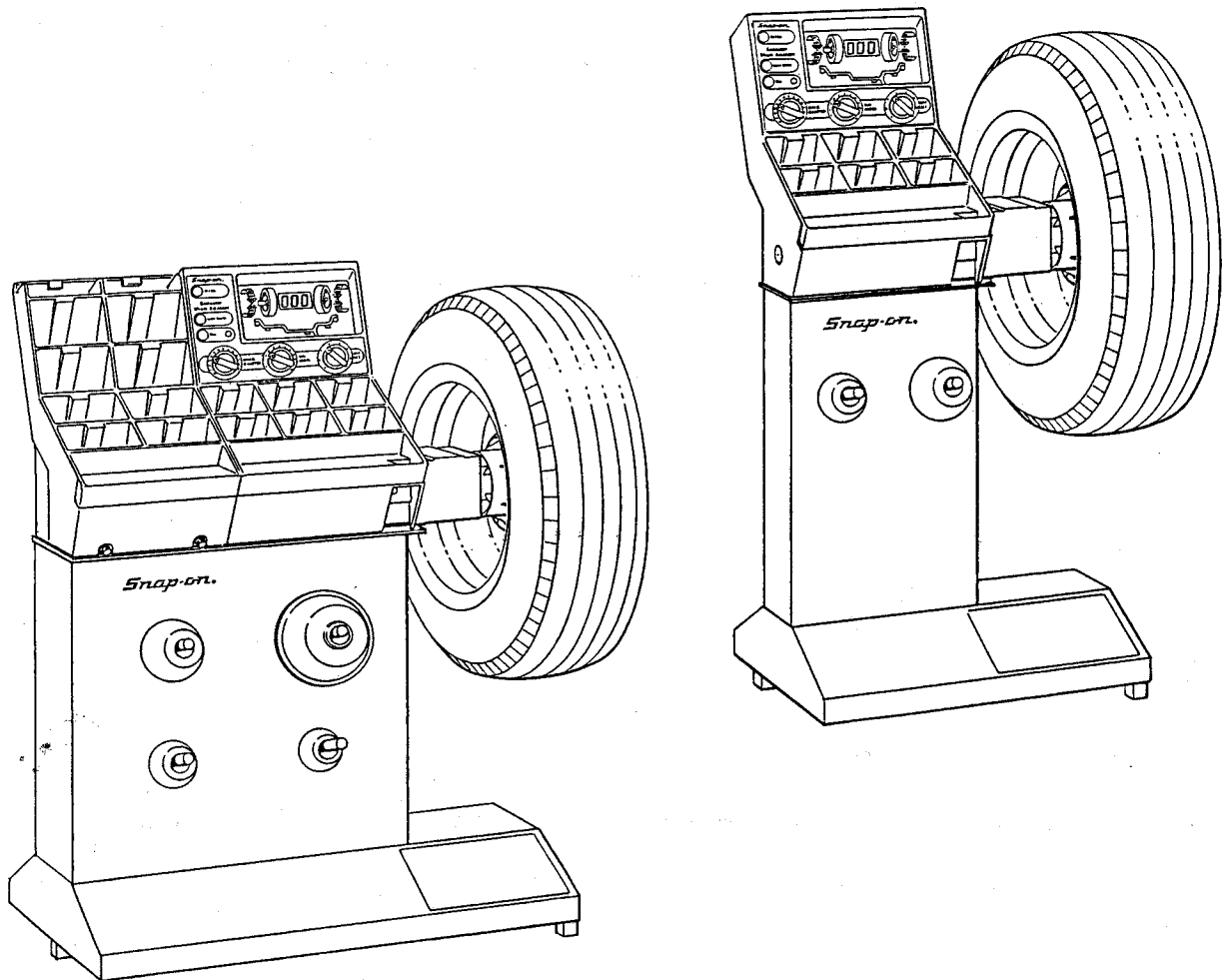

Precision Wheel Balancers

Snap-on®

Safety Cautions and Warnings

Before operating the balancer for the first time, review the following safety precautions.

1. Wear approved eye protection when removing and attaching weights.
2. Make sure the power switch on the left rear of the balancer is OFF before plugging or unplugging the balancer.
3. The standard power converter supplied with WB250 and WB260 balancers operates from a 115 vac, 50/60 Hz power source and converts the line voltage to 8.5 vac. The balancers may also operate directly from 12 vdc. Other converters are available.
4. The balancer automatically returns to the *Normal* balancing mode if power is interrupted.
5. Make sure the balancer is sitting on all three feet on a clean, level floor with no debris under the base.
6. Remove all stones, old weights, heavy dirt, and other debris from the wheel before balancing.

The information and specifications in this manual are based on the latest information available at the time of publication. The balancer manufacturer and the vehicle manufacturers reserve the right to make equipment changes at any time without notice.

Copyright © 1993 Snap-on Tools Corporation

WB250, WB260A User's Manual

Contents

	Page
Introduction	3
Features	3
Description	4
Accessories	4
Standard	4
Optional	4
Balancer Controls and Indicators	5
Balancing Operation	6
Operating summary	6
Balancing errors	7
Automatic Weight Recalculation for Custom Weight Location	8
Static balancing	8
Automatic Calibration	9
Calibration procedure	9
Calibration error	9
Wheel Mounting Methods	10
Back cone mounting	10
Back cone mounting without pressure drum	10
Front cone mounting	10
Double cone mounting	11
Front cone mounting with an extension adapter	11
Mounting errors	11
Rotational errors	11
Tire and Wheel Matching (Weight Compensation)	12
Service and Repairs	13
Preventive maintenance	13
Printed Circuit Board and Display Panel Removal	13
Weight Tray and Control Housing Removal	14
Measuring Head and Sensor Panel Removal	14
Brake Adjustment	16
Specifications	16
WB250 and WB260A Parts List	17
APPENDIX — Special Mounting Adapters	19
Mounting with the universal wheel adapter	19
Mounting with the metric bolt plate adapter	20
Mounting with the motorcycle adapter kit	20
Stub Shaft Installation	Inside Back Cover

For service or parts assistance, call: 1-(800) 332-2526

Second Edition: November 1993

INTRODUCTION

The Snap-on WB250 and WB260A computerized wheel balancers combine state-of-the-art electronic accuracy with ease of use and simplicity of design. Your Snap-on balancer will give you years of reliable operation and wheel balancing profits. Take a few minutes to study this manual before operating your Snap-on balancer for the first time.

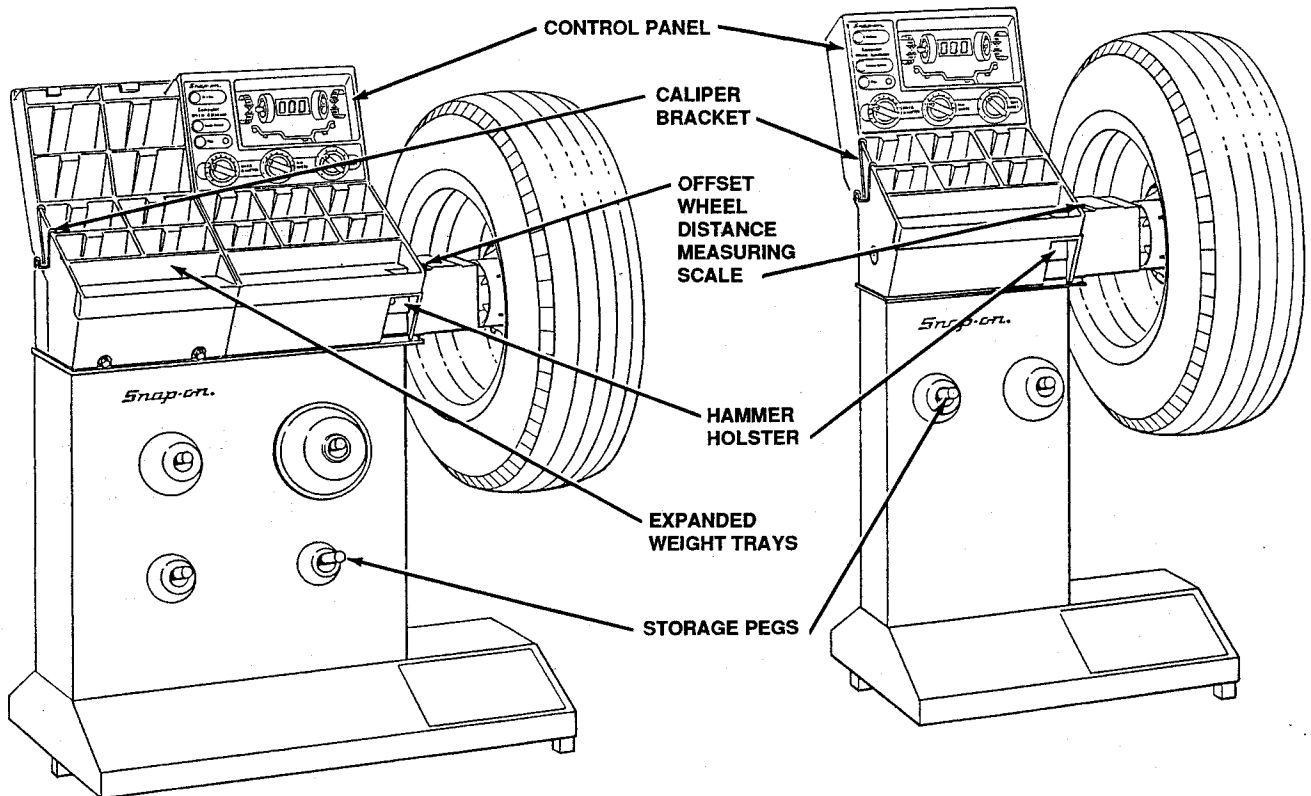

Figure 1. The WB250 and WB260A are hand-spun precision wheel balancers. (The WB260A offers expanded weight trays.)

FEATURES

The Snap-on WB250 and WB260A represent today's most advanced concepts in wheel balancing with these high-precision features:

- **Safe, accurate, low-speed operation** — Balance wheels to 0.10-ounce (2-gram) accuracy at an operating speed of only 90 rpm.
- **Fast and simple** — With a single spin cycle of only 7 seconds and a large display that shows the exact weight requirement and location, the Snap-on balancers promote productivity and profits.
- **Electronic simplicity** — All major components can be replaced in the field, and the automatic self-calibration program allows the balancer to calibrate itself with little or no downtime.
- **Six balancing modes and automatic weight placement recalculation** — The balancers have six balancing modes:
 - *Normal* for standard clip-on weights on the inner and outer rim flanges
 - *Static* for motorcycle wheels and some specialty wheels.
 - Four *Custom* modes for combinations of clip-on and stick-on weights, including hidden-weight balancing.Balance the wheel in the *Normal* mode and then let the balancer recalculate the weight requirements for any of the four *Custom* weight locations.

DESCRIPTION





The WB250 and WB260A are hand-spun balancers. All operating instructions, measurement entries, and results are displayed on an easy-to-read control panel with bright, light-emitting diode (LED) indicators. This, plus the other following features, allows any operator to balance wheels and tires in the shortest possible time with the highest accuracy.

- **Control Panel —**
The panel and its LED indicators display the wheel and tire dimensions and operating mode selected by the operator, as well as the results of all operations.
- **Weight Trays and Hammer Holster —**
Trays for holding assorted weights and a weight hammer holster are located at operator working level.
- **Offset (Wheel Distance) Measuring Scale —**
For easy use and accurate reading, the wheel offset scale is located at the right front of the balancer console.
- **Storage Pegs and Caliper Bracket —**
The balancer base has four pegs for convenient storage of adapters and other tools, leaving the work area uncluttered. A caliper bracket attaches to the left side of the weight tray for convenient caliper storage.
- **Power Switch (left rear, not shown) —**
A single switch on the left rear controls power for the balancer.

ACCESSORIES

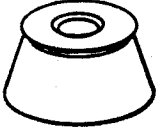
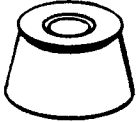
Your Snap-on balancer is equipped with the standard accessories listed below. Several optional accessories also are available.

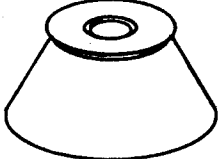
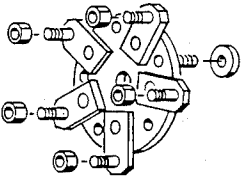
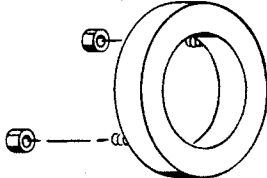
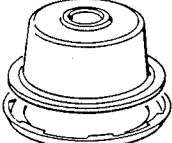
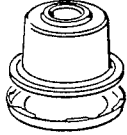
Standard

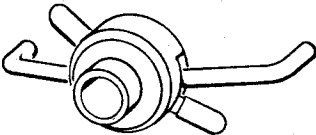
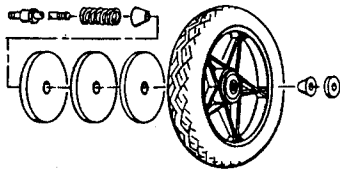
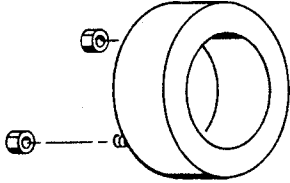
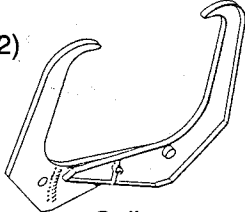
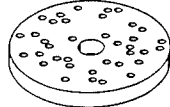
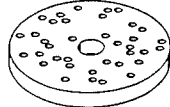
					
Cone spring (WB1131)	Large cone (WB1090-01)	Medium Cone (WB 1090-02)	Small cone (WB1090-03)	Extra small cone (WB1090-04)	Truck Cone (WB1133-01)
					
Universal wheel adapter (WBA2) used to fit 3-, 4-, 5-, 6-, 8-, and 10-hole bolt patterns.	Extension adapter (WBA1-A) used for high-offset wheels, such as Ford F350.	Large drum (WB1140-01) Gasket (WB2533-01)	Small drum (WB1140-02) Gasket (WB2533-02)	Caliper Bracket (WB2543)	Hub nut Handle (WB1329)
					
Quick hub nut handle (WB1685)	Motorcycle adapter (WBM1419)	Extra-wide extension adapter (WBA1-B), used to move high-offset wheels away from the machine.	Calipers (WB1158-02)	Metric Bolt plate adapter (WB1499)	Metric Bolt plate adapter (WB1499)

BALANCER CONTROLS AND INDICATORS

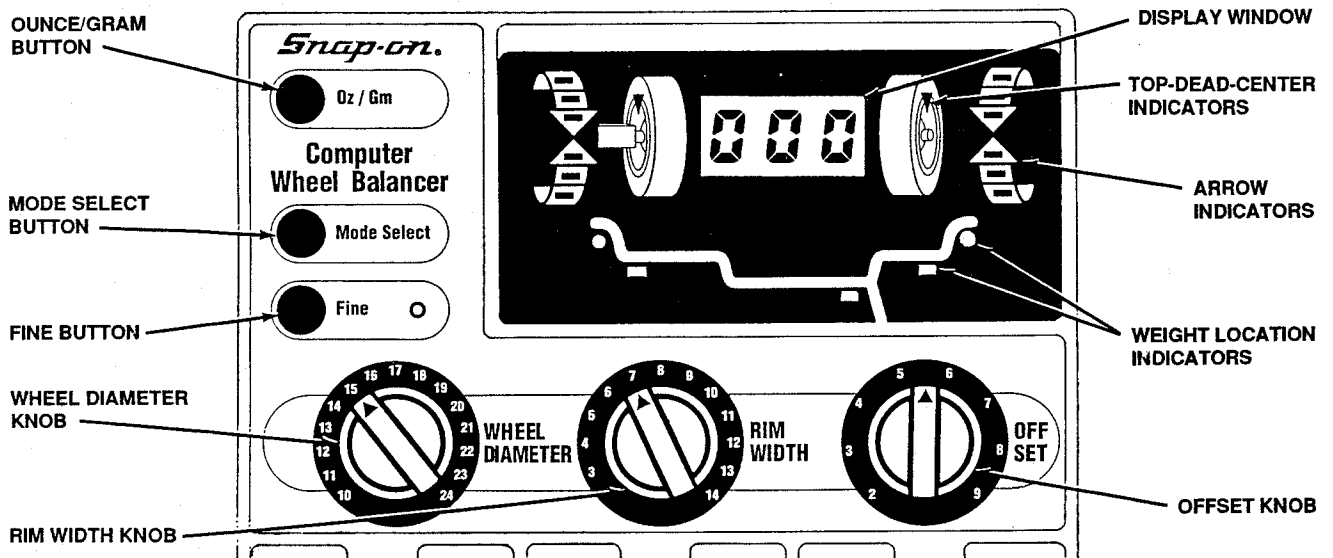

FIGURE 2. Balancer controls and indicators.

- Ounce/Gram Button —**
 The Ounce/Gram button alternately changes displayed readings from ounces to grams.
 - Mode Select Button and weight location LED indicators—**
 The Mode Select button works in conjunction with the LED indicators on the display. It selects the balancing mode and weight location. Weight requirements are automatically recalculated when the mode is changed.

 For easy and accurate *Custom* mode operation, do the balancing operation in the *Normal* mode. Then press the Mode Select button for the desired custom weight location. The balancer will automatically recalculate the amount of weight required for the selected weight location. Press the button repeatedly until the correct combination of LED's lights for the desired weight location.
- | Mode | Select Button | Mode | Lights On |
|------|---------------|----------|-----------|
| | | Normal | 1+5 |
| | x1 | Custom 1 | 1+4 |
| | x2 | Custom 2 | 2+4 |
| | x3 | Custom 3 | 1+3 |
| | x4 | Custom 4 | 2+3 |
| | x5 | Static | 3 |
- WHEEL DIAMETER Knob —**
 Turn the WHEEL DIAMETER knob to set rim diameter. Read the selection in the display window. Numbers 10 to 17 on the dial are for automotive applications, numbers 18 to 24 are for motorcycle rims.
 - RIM WIDTH Knob —**
 Turn the RIM WIDTH knob to set rim width. Read the selection in the display window.
 - OFFSET Knob —**
 Turn the OFFSET knob to set rim offset, or distance. Read the selection in the display window.
 - Display Window —**
 The LED's in the display window indicate the diameter, width, and offset selections as each is entered into the balancer. After the balance spin, the display window indicates the weight (in grams or ounces as selected) to be placed at top dead center when the appropriate top-dead-center indicator is lit.
 - Arrow Indicators —**
 The arrows light sequentially as the correct position for weight placement is approached.
 - Top-Dead-Center Indicators —**
 The Top-Dead-Center indicator for the inner or outer rim flange lights when all six arrow lamps are on for the inner or outer weight placement.
- To enter calibration, press and hold the Fine and Mode buttons for 2 to 3 seconds. Refer to the Automatic Calibration section for more details.

BALANCING OPERATION

Operation of your Snap-on balancer is based on LED indicators on the control panel three soft-touch buttons and three control knobs that allow you to enter all information needed for precision balancing. The display indicates dimensions as they are entered.

Operating Summary

The following summary covers the nine main steps for fast, accurate wheel balancing with your Snap-on balancer. Later sections of this manual contain detailed information on all balancing modes and wheel mounting methods for your Snap-on balancer.

CAUTION: Wear approved eye protection when removing and attaching weights.

1. Make sure the power switch is ON.
2. Mount the wheel.

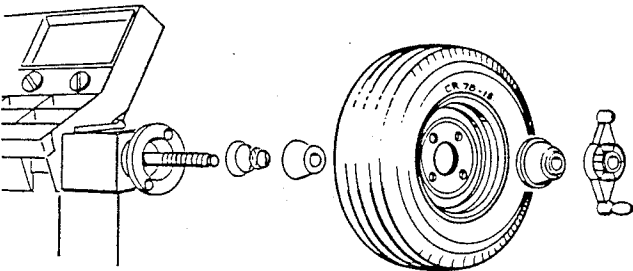

- a. For standard back-cone mounting, choose the cone that fits best when placed through the wheel center hole from the rear. Slide the cone spring and cone onto the shaft as shown. The cone must center the wheel.
- b. Place the wheel on the cone.
- c. Choose a pressure drum that contacts the wheel on a flat surface. Do *not* center the wheel with the drum.
- d. Slide the hub nut handle onto the shaft and tighten the wheel firmly against the cone and the balancer flange. During the last few turns, hold the handle in place and rotate the wheel to tighten. The wheel must be firm against the flange and centered with the cone. The handle threads must engage at least three turns.

Most original equipment and aftermarket wheels can be mounted with some combination of the standard Snap-on mounting adapters. Refer to the *Wheel Mounting Methods* section of this manual for more instructions.

3. Depress the Mode Select button until LED's 1 and 5 light to indicate the *Normal* balancing mode.

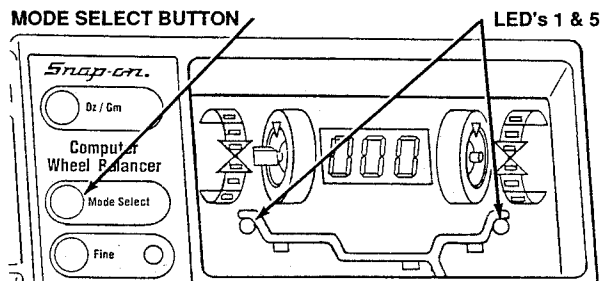

4. Set the WHEEL DIAMETER knob to the diameter shown on the sidewall.

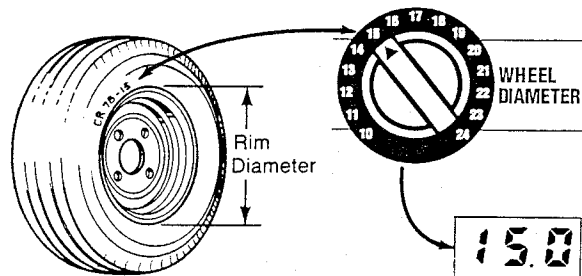

The display will show the selected diameter.

5. Measure the wheel width with a caliper.

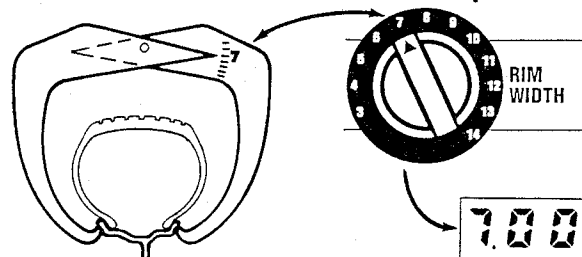

Adjust the RIM WIDTH knob to the correct setting, as shown on the display.

6. Set the rim offset, as follows:

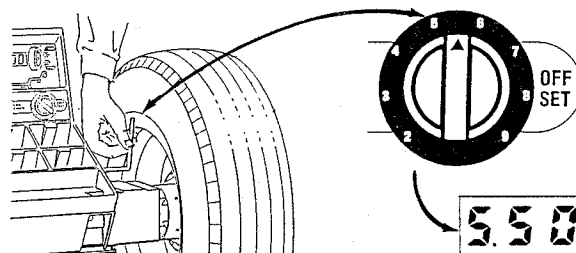

The display will show the selected offset.

- a. Pull the rim offset gauge arm out and position the tip against the rim flange surface (regardless of where the inner weight will be placed).

- b. Read the rim distance value off the gauge arm at the point where it enters into the housing.
- c. Set the RIM DISTANCE knob to the rim distance value.

7. Spin the wheel.

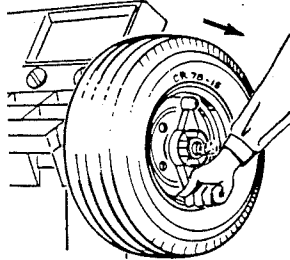

Spin the wheel by hand using the crank handle. Turn the crank handle clockwise until buzzing is heard and the display goes blank. Immediately release the handle and allow the wheel to spin freely until the measuring cycle is complete and the spinning stops.

Normal balance speed is approximately 90 rpm. If spun too fast, the buzzer will sound continuously until the wheel slows to proper measurement speed. The balancer will function normally even when a wheel is spun too fast. However, balancer cycle time will increase.

If the wheel is handspun in the wrong direction (counterclockwise), EEE will appear on the display and the brake will not function. Turning the wheel clockwise will remove EEE from the display and allow the balancer to function properly.

Do not interfere with the machine during the measuring cycle or wrong readings can occur.

8. Attach the weight:

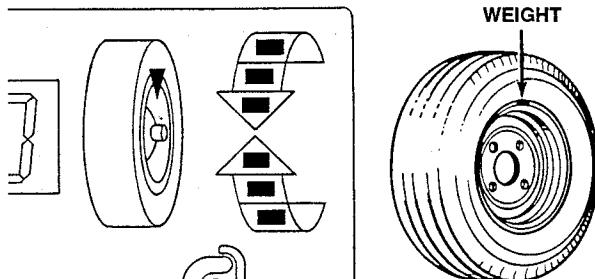

- a. Starting with either side of the wheel, rotate the wheel in the direction of the lit arrow until all arrows light indicating the correct position. The top-dead-center light and the correct weight will be displayed.
- b. If you want a normal mode balance, attach the weights now. If you want a custom balance, see the next section.
- b. Securely apply the indicated weight at the top-dead-center location.
- c. Repeat 8a and 8c for the other side of the wheel. Make sure that the stick-on weights will clear the vehicle disc brake caliper.

9. Do a check spin.

Repeat the spin cycle. Zero weight readings should appear for both sides of the rim.

OPTIONAL: Fine balance to 0.10-ounce accuracy — Standard balancing in all modes indicates weight in 0.25-ounce increments to a final accuracy of 0.25-ounce. Press the Fine button at the left side of the control panel for final balancing to 0.10-ounce accuracy.

It is not necessary to spin the wheel again. The balancer calculates the fine balancing requirements from the previous measurements, and the display will show weight requirements to a final accuracy of 0.10-ounce (2-grams).

Balancing Errors

If you handspin the wheel in the wrong direction — *counterclockwise* — during balancing, the EEE message appears on the display as explained in step 6 above. Although not common, other errors may occur during a balancing cycle. For example, the measurement cycle may be aborted by stopping the wheel too soon.

When a balancing error occurs, the EEE message appears on the display. You can clear any error by spinning the wheel up to balancing speed.

AUTOMATIC WEIGHT RECALCULATION FOR CUSTOM WEIGHT LOCATION

The Snap-on balancers feature one normal and four custom balancing modes for combinations of clip-on and stick-on weights, including hidden-weight balancing. A static balancing mode also is included.

The LED's on the display panel indicate the desired weight locations, as shown below. When placing the weights for any of the Custom modes, observe the position location dimensions shown. The balancer is programmed for these positions only, other placement positions may require different weights.

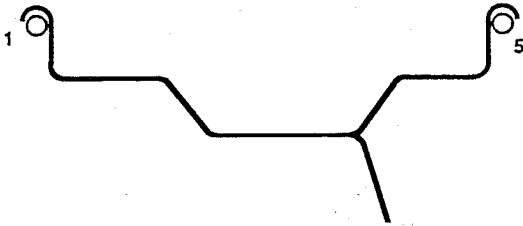

Normal — LED's 1 and 5 light to indicate standard clip-on weights on the inner and outer rim flanges.



Custom 1 — LED's 1 and 4 light to indicate a standard clip-on weight on the inner flange and a stick-on weight on the outer bead-seat area of the rim.

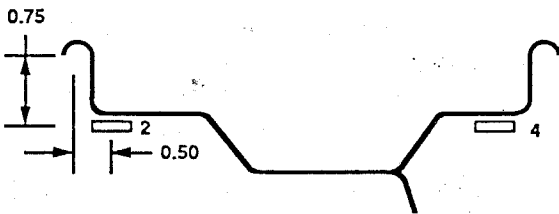

Custom 2 — LED's 2 and 4 light to indicate stick-on weights on the inner and outer bead-seat areas of the rim.

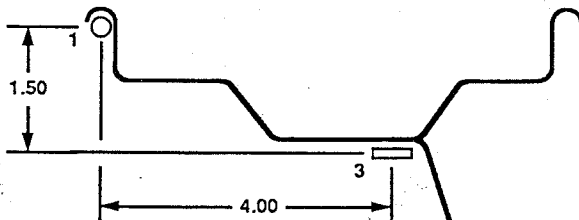

Custom 3 — For this hidden-weight method, LED's 1 and 3 light to indicate a standard clip-on weight on the inner flange and a stick-on weight toward the center well (drop center) inboard area of the rim.

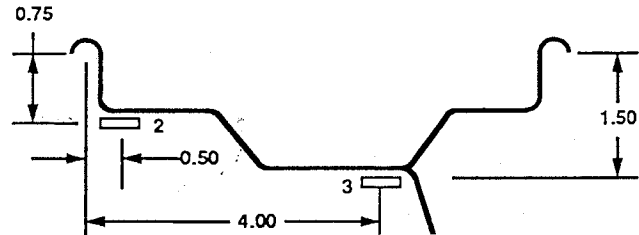

Custom 4 — For this hidden-weight method, LED's 2 and 3 light to indicate a stick-on weight on the inner bead-seat area and a stick-on weight toward the center well (drop center) inboard area of the rim.

When using the Custom 3 or Custom 4 mode, the inner and outer weights must be placed 4 inches apart longitudinally for accurate balancing. The balancer is programmed for a standard weight spacing of 4 inches for these modes.

For simple and accurate balancing, the *Normal* mode can be used for all balancing measurements. After the balancing spin cycle, press the Mode Select button until the LED indicators light for the desired *Custom* mode weight locations. The balancer will automatically recalculate the amount of weight required for each custom location.

Static Balancing

For static balancing, the rim width and offset dimensions do not need to be entered into the balancer. Simply enter the wheel diameter and press the Mode Select button to select the static balancing mode. After the spin cycle, the inner weight LED's and TDC indicator will light to show the required weight amount and location. The weight can be placed on the inner or outer rim flange or toward the center of the rim. The amount of weight also can be divided equally between the inner and outer rim flanges.

If you enter the rim width, offset, and diameter and spin the wheel in the *Normal* balancing mode, you can select the static mode after the spin cycle; and the balancer will recalculate the amount and location of the weight for static balancing.

AUTOMATIC CALIBRATION

The Snap-on WB250 and WB260A balancers are calibrated by computer before shipment and should not require recalibration in normal service. If the electronics assembly or the back panel assembly is replaced, however, the balancer should be recalibrated. Additionally, if balancing results appear to be irregular, the balancer may require recalibration. The WB250 and WB260A contain a program for automatic self-calibration, which can be performed in about the same time that it takes to balance a single wheel.

Calibration Procedure

Follow this procedure to calibrate your balancer:

1. Fine balance a wheel

Fine balance a wheel as explained in the *Balancing Operation* section. Use a wheel of the kind and size normally balanced on the balancer. The wheel must be balanced in the NORMAL mode. If the balancer is in the STATIC mode or any of the Custom modes, the calibration program will not operate.

To fine balance a wheel after standard balancing to 0.10-ounce accuracy, press the Fine button on the control panel. Then attach additional weight as indicated for fine balancing to 0.10-ounce accuracy.

2. Attach a 3-ounce (100-gram) weight.

Rotate the wheel until both outer position arrows and the top-dead-center indicator light. Attach a 3-ounce weight (or 100-gram, depending on the selected measurement units) to the outer wheel rim at TDC.

3. Enter the calibration program.

With 000 displayed, press and *hold* the Fine button. While *holding* the Fine button, press the Mode Select button for 3 to 4 seconds. When the balancer enters the calibration program, the display will show a flashing CCC.

4. Spin the wheel at least four times.

Spin the wheel using the normal balancing cycle.

Turn the hub handle *clockwise* until the buzzer sounds. Release the handle and let the wheel spin freely until the cycle is complete (approximately 7 seconds). The brake engages automatically.

If you spin the wheel too fast, the buzzer will sound continuously until the wheel slows to measuring speed. The calibration program operates normally and accurately, but calibration time will be increased.

After the wheel stops and the flashing CCC message reappears, spin the wheel again. Calibration usually requires four consecutive, accurate spins.

After the final accurate spin, the calibration weight will appear on the display for the outer rim flange and three zeros will appear for the inner flange. Calibration is now complete.

5. Remove the calibration weight.

After successful calibration, the balancer stores the new calibration values in memory. Remove the calibration weight from the wheel and proceed with normal operation of your balancer.

If calibration is abandoned before completion, the original (previous) calibration values are retained.

Calibration Error

If an error occurs during any of the spin cycles, the EEE error message appears on the display. The calibration program is aborted, and the balancer retains the previous calibration values.

The EEE error message may result from using an incorrect calibration weight. Accidentally bumping the balancer during calibration also could cause an error message. To correct a calibration error, remove the calibration weight and spin the wheel to remove the EEE's. Then, verify that the wheel is still balanced and repeat the calibration procedure.

If calibration fails, try the calibration program again from the beginning. Changing the wheel and the 3-ounce calibration weight may correct a calibration failure. If the balancer repeatedly fails the calibration program, contact your Snap-on dealer for assistance.

For calibration assistance, call: 1-(800) 332-2526

WHEEL MOUNTING METHODS

Careful mounting is essential because the wheel is balanced according to how it is mounted on the balancer. If the wheel is not well centered, it cannot be balanced accurately.

Most stud-centered wheels have concentric center holes, which allow fast and easy cone mounting. Adapters should be used only in problem situations and on some aftermarket specialty wheels.

The accessories supplied with your Snap-on balancer allow the following wheel mounting methods.

Back Cone Mounting

Back cone mounting is the most common way to mount automobile wheels. Choose the cone that fits best when placed through the wheel center hole from the rear. Slide the cone spring and cone on the shaft. Place the wheel on the cone and be sure that the *cone centers the wheel* when you tighten the handle.

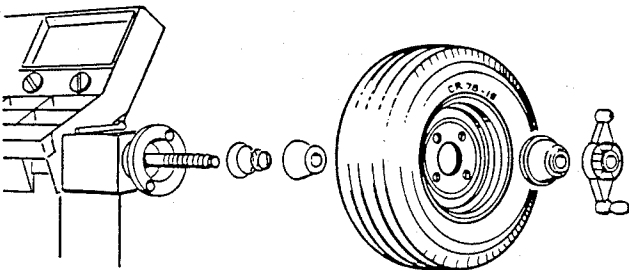

Choose a pressure drum that contacts the wheel on a flat surface. Do not center the wheel with the pressure drum. Tighten the wheel firmly against the mounting flange. Hold the handle in place and rotate the wheel when tightening. Be sure that the wheel is *firmly against the mounting flange* and the handle threads engage at least three turns on the shaft.

Back Cone Mounting Without Pressure Drum

CAUTION: Be sure that the handle does not contact the cone, or the wheel will not be centered and mounted securely.

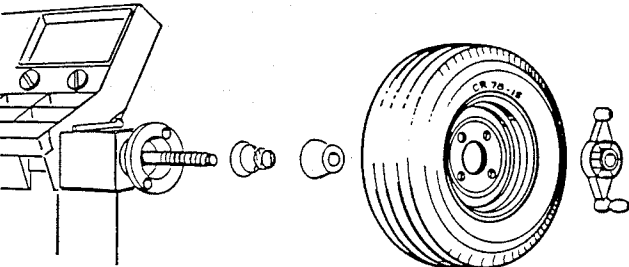

On some extended-center wheels with small hub diameters, the pressure drum cannot contact the front face of the wheel properly. Such wheels can be mounted using the standard back cone method without a pressure drum. Be sure that the handle contacts the wheel center evenly and that the wheel is centered on the cone.

Front Cone Mounting

Front cone mounting is required when using the light truck cone and is also an acceptable alternative for many automobile wheels. The wheel center hole must be true on the outside of the wheel to use the front cone mounting method.

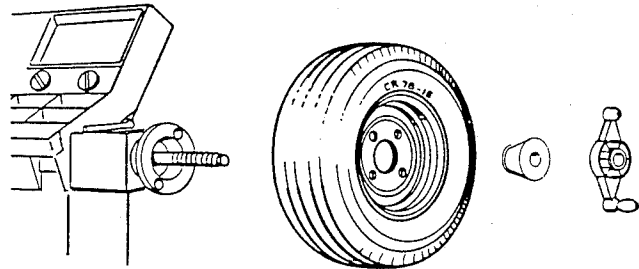

Choose the cone that fits best when placed through the wheel center hole from the front. Slide the wheel on the balancer shaft without a back cone or spring on the shaft. Place a cone on the shaft, through the front of the wheel. Be sure that the *cone centers the wheel* and that the wheel is squarely against the mounting flange when you tighten the handle.

Double Cone Mounting

CAUTION: The cones must not touch each other. If the cones touch, the wheel will not be centered and mounted securely.

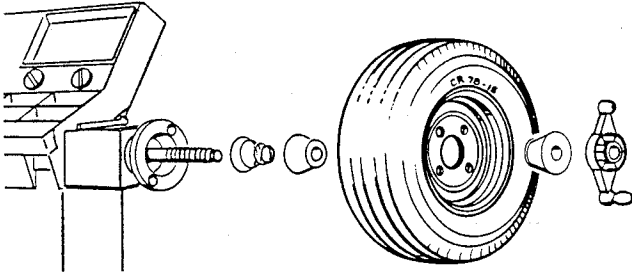

Double cone mounting can be used for some specialty wheels, such as those on a Porsche 928. The back cone centers on the formed part of the wheel, and the front cone centers on the hole.

Front Cone Mounting With An Extension Adapter

The extension adapter may be required for some light truck wheels and reverse-offset wheels that must be moved away from the balancer mounting flange. The extension adapter is used often with the 5-1/2-inch diameter light truck cone.

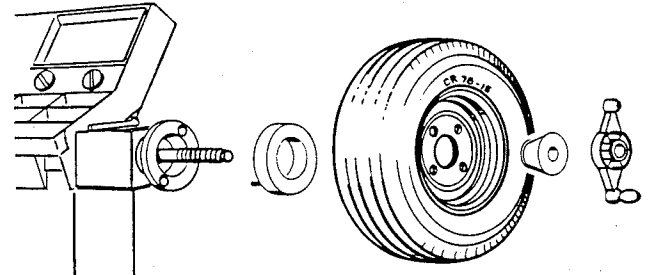

Install the extension adapter on the mounting flange with the knurled thumbnuts provided. Then mount the wheel, using the normal front cone method.

Mounting Errors

Regardless of the mounting method used, *the wheel must be centered* before balancing. A wheel should be mounted on the appropriate cone or adapter and tightened carefully to ensure proper centering and mating against the balancer flange.

The wheel must be clean and free of large burrs or nicks, especially where it mates with the cone or adapter and the balancer flange. Any dirt between the flange and the mating surface of the wheel will cause misalignment on the shaft. A misalignment of the thickness of a matchbook cover will cause an unbalance of 0.50 ounce (15 grams) or more on automobile wheels and 1 ounce (30 grams) on light truck wheels.

The wheel also must be tightened securely to prevent it from slipping in relation to the flange. If the wheel slips on the balancer, accurate weight measurement and location are impossible.

Rotational Errors

When a wheel is mounted on the balancer — whether on a cone or an adapter — it is fixed in a particular position in relation to the balancer shaft. If the wheel is rotated 180° from the initial position and retightened, a different balance reading may result. Such differences are called *rotational errors*.

When checking balance with the wheel in one position and then rotating it 180° and respinning it, the difference between the two readings could be as much as 0.50 ounce (15 grams) for cone-mounted automobile wheels, 0.75 ounce (20 grams) for adapter-mounted automobile wheels, and 2 ounces (60 grams) for light truck wheels.

The actual balance error is one-half of the displayed amount because the reading is the sum of the error and the weight required to counterbalance the error.

To do a rotational test, first fine-balance the wheel. Then loosen the wheel on the shaft, rotate it 180°, and retighten the handle. Spin the wheel in the normal balance mode to check for rotational errors.

TIRE AND WHEEL MATCHING (Weight Compensation)

Wheel balancing can sometimes be improved by wheel and tire matching, or adjusting the tire position on the wheel to compensate for light and heavy spots in the wheel and tire. This may be beneficial if the wheel, or the tire-and-wheel assembly, has visibly noticeable radial runout when spun through a balancing cycle on the balancer. Tire and wheel matching also may aid the balancing operation by reducing the required weight if weight exceeds 4 ounces. If neither of these two conditions exists, tire and wheel matching probably will not significantly improve balancing.

The WB250 and WB260A model balancers can be used to aid tire and wheel matching in either of the two ways explained below. Weight measurements should be taken in the *STATIC* balance mode. This can be done either by entering just the wheel diameter and spinning the wheel in the static balance mode, or by entering all wheel dimensions and spinning the wheel in a normal balance cycle. Then press the Mode Select button for the static mode, and let the balancer recalculate the static weight measurement.

For either method, begin by removing all old weights and any dirt or debris from the wheel and tire.

Method One

1. Mount the wheel by itself — without a tire — on the balancer.
2. Spin the wheel for a balance cycle.
3. Note the static weight location indicated by the balancer. This is the light spot of the wheel. Place a chalk mark on the rim at this location.
4. Mount the tire on the wheel and repeat the balance cycle.
5. Again note the static weight location indicated by the balancer. This is the light spot of the wheel and tire combination. Place a chalk mark on the tire at this location.
6. If the light spot of the wheel and the light spot of the wheel-and-tire combination are at the same, or close to the same location, loosen the tire on the rim and rotate it 180 degrees so that the two light spots are opposite each other.
7. Reinstall the wheel and tire on the balancer and proceed with normal dynamic balancing.

If the light spot of the wheel and the light spot of the wheel-and-tire combination are *not* at or close to the same location, balance will not be improved significantly by repositioning the tire on the wheel.

Method Two

1. Mount the wheel and tire on the balancer and spin the wheel and tire for a balance cycle.
2. If the amount of static imbalance *exceeds 4 ounces* (for any diameter wheel), place chalk marks on the wheel and on the tire at the weight location indicated by the balancer.
3. Remove the wheel and tire from the balancer and loosen the tire on the rim. Rotate it 180 degrees so that the two light spots are opposite each other.
4. Reinstall the wheel and tire on the balancer and proceed with normal dynamic balancing.

If the static imbalance of the wheel-and-tire combination does *not exceed 4 ounces*, balance will not be improved significantly by repositioning the tire on the wheel.

SERVICE AND REPAIRS

Your Snap-on balancer is completely field serviceable. The balancer also can be serviced at your Snap-on service center. If your balancer appears to malfunction (for example, brake does not work, cycle time is too long, modes do not light), reset the computer by turning the power switch OFF and ON. Replacement parts and service assistance are available from your Snap-on dealer. For factory assistance, call: 1-(800) 332-2526.

Preventive Maintenance

1. Clean mounting adapters, mounting surface, and balancer spindle regularly. Accumulations of grease, oil, and dirt create an out-of-balance condition and cause premature wear.
2. Remove wheel weights and debris from under the balancer. Remove tires, tools, and any parts leaning against the balancer. Make sure the balancer rests only on the three foot pads.
3. Clean the control panel with window cleaner. *Do not* use solvents.

Printed Circuit Board and Display Panel Removal

Remove and replace the PC board and display panel, figures 3, 4, and 5, as follows:

1. Disconnect ac power from the balancer.
2. Remove the four Phillips screws from the control housing back cover and remove the cover.
3. Disconnect the two cable connectors from the back of the PC board.

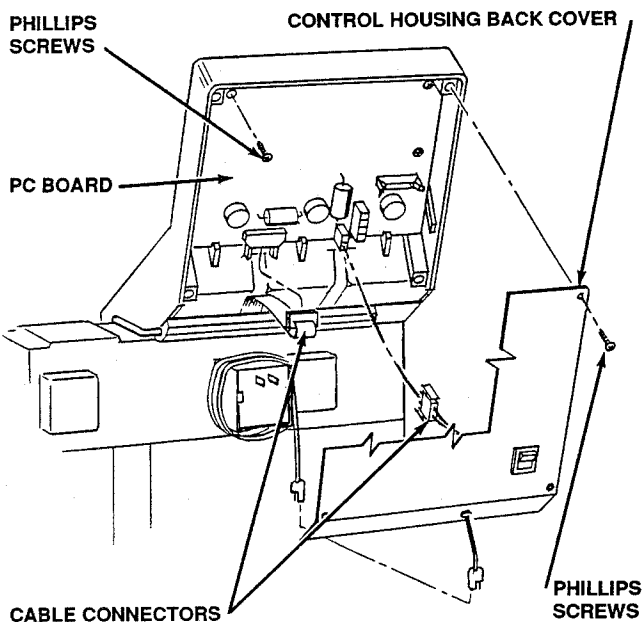

Figure 3. Removing the WB250 printed circuit board and display panel (rear view).

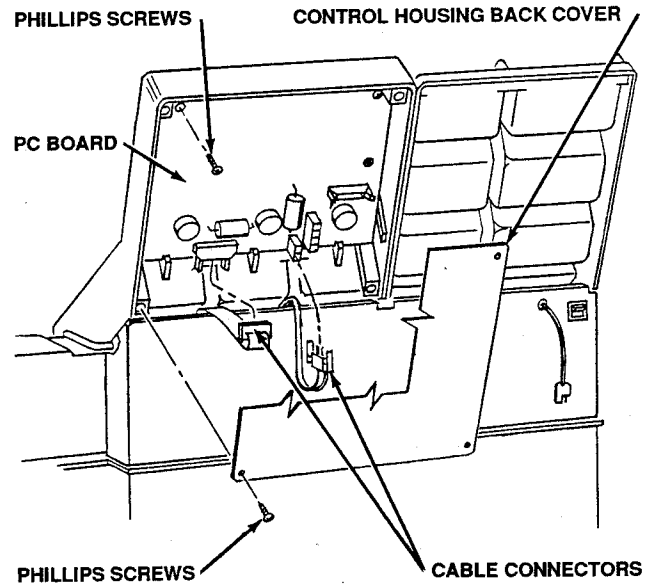

Figure 4. Removing the WB260A printed circuit board and display panel (rear view).

4. Pull off the three control knobs from the front panel.

CAUTION: Do not loosen the two small nuts on the lower left of the PC board. They secure a transistor and heat sink to the board.

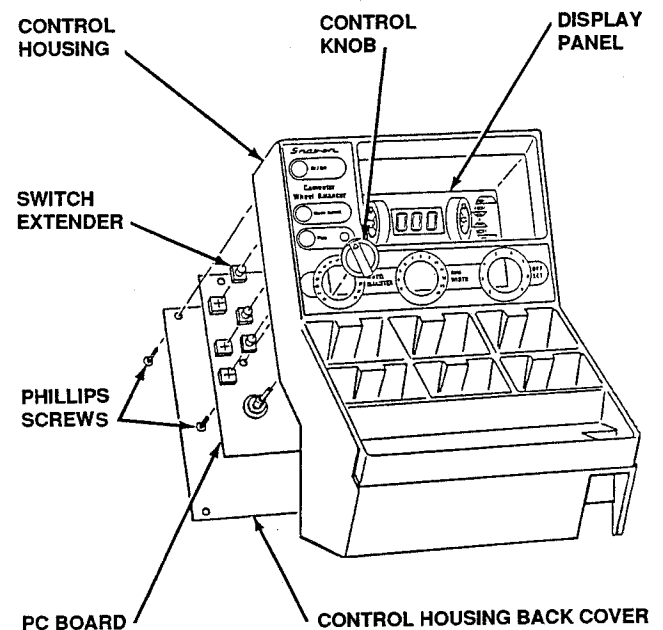

Figure 5. Removing the WB250 and WB260A printed circuit board and display panel (front view).

5. Remove the three Phillips screws from the back of the PC board and remove the PC board and display panel assembly from the housing.
6. Remove the switch extenders from the three pushbuttons on the PC board and install them on the new board.
7. Install the replacement PC board and display assembly, secure with three Phillips screws.
8. Reconnect the two cable connectors to the back of the PC board and reinstall the back cover.
9. Reconnect ac power.

Weight Tray and Control Housing Removal

Remove the balancer weight tray and control housing, figures 6 and 7, as outlined below. Be sure to remove all weights and other material from the trays before removing them from the balancer.

1. Remove the left-hand weight tray for WB260A models as follows:
 - a. Use a 1/2-inch socket to remove the two hexhead screws and washers, located on the lower face of the weight tray.
 - b. Remove two Phillips screws and washers from the weight pockets.

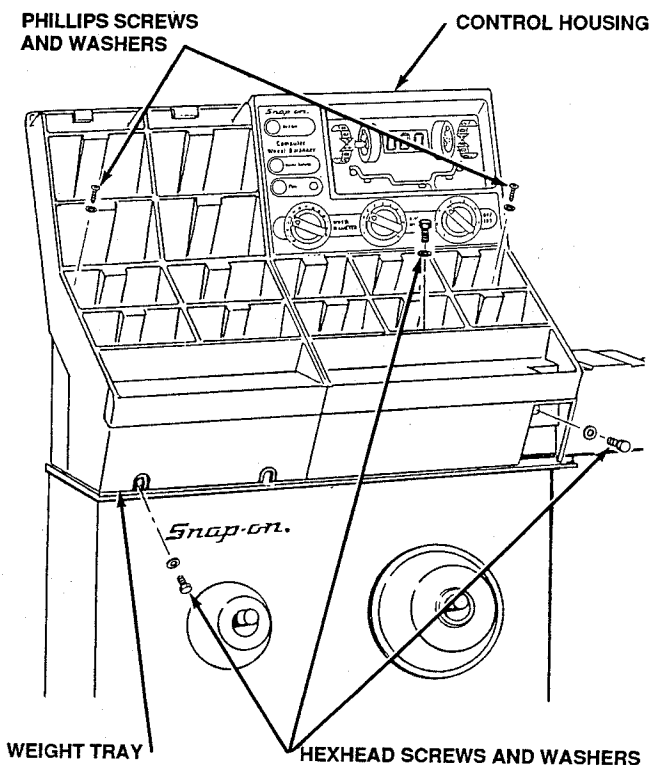

Figure 6. Removing the WB260A weight tray and control housing.

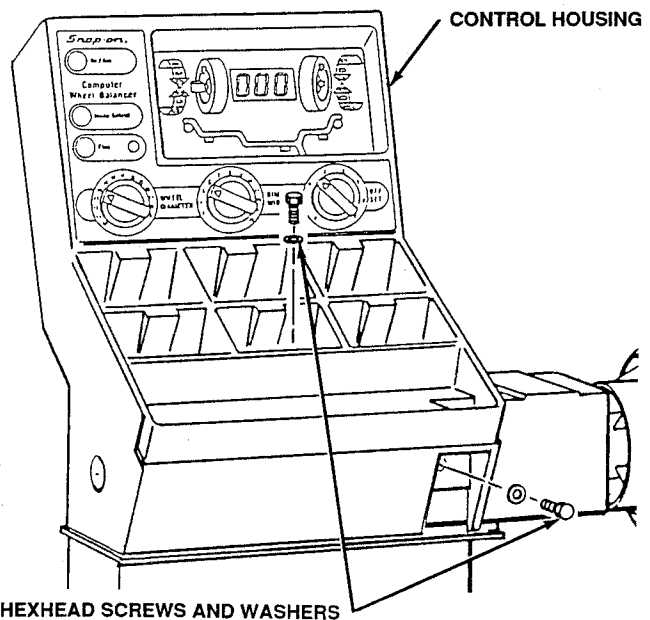

Figure 7. Removing the WB250 weight tray and control housing.

2. Remove the control housing as follows:
 - a. Remove the PC board and display panel assemblies as described previously. If you are removing the control housing for access to the measuring head and sensor assembly, leave the control knobs and the PC board and display attached to the weight tray.
 - b. Use a 1/2-inch socket to remove the two hexhead screws and washers. One screw is located on the lower face of the weight tray, the other is located in a weight tray pocket.
 - c. On WB260A models, remove two Phillips screws and washers from the weight pockets.

Measuring Head and Sensor Panel Removal

Remove and replace the measuring head and sensor panel assemblies, figures 8, 9, and 10, as follows:

1. Disconnect ac power from the balancer.
2. Remove the weight tray (WB260A only) and control housing as described previously.
3. On WB 260 models:
 - a. Use a 1/2-inch open-end wrench, or a 1/4-inch Allen wrench (as required), to remove the two hexhead screws and washers below the outboard end of the measuring head.

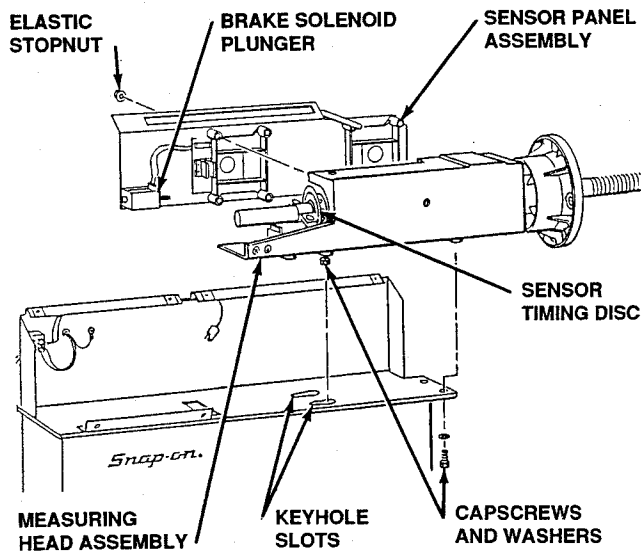

Figure 8. Removing the WB260A measuring head and sensor panel assemblies (front view).

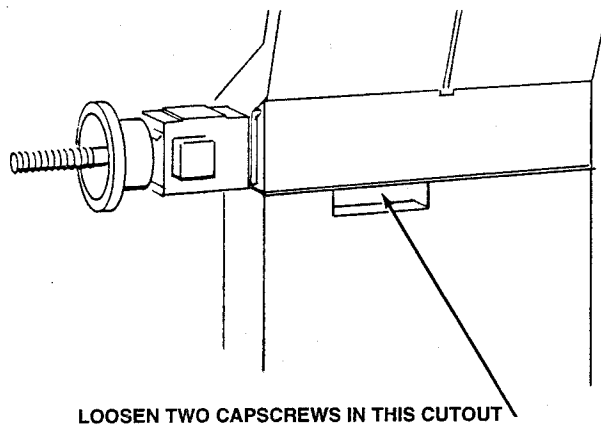

Figure 9. Removing the WB260A measuring head and sensor panel assemblies (rear view).

- b. Use a 1/2-inch open-end wrench, or a 1/4-inch Allen wrench (as required), to *loosen* the two capscrews below the inboard end of the measuring head. These are located inside the cutout at the rear of the balancer. The capscrews fit into keyhole slots on the balancer base. Loosen them a few turns; do not remove them.
4. On WB 250 models:
 - a. Use a 1/2-inch open-end wrench, or a 1/4-inch Allen wrench (as required), to *loosen* the two capscrews and washers below the outboard end of the measuring head. The capscrews fit into keyhole slots on the balancer base. Loosen them a few turns; do not remove them.

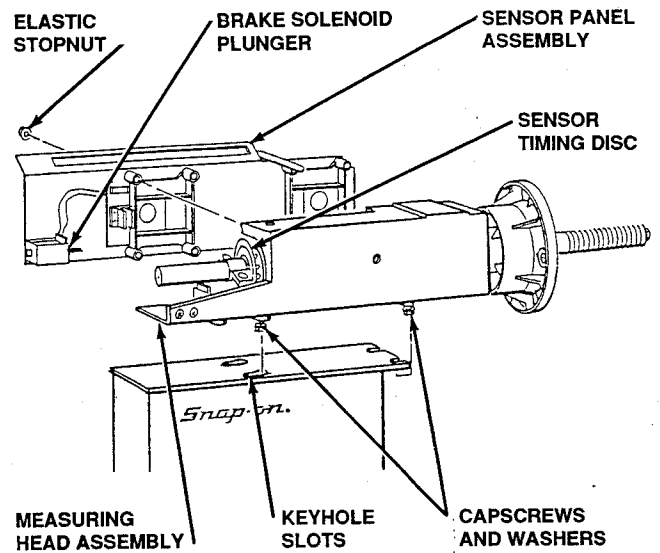

Figure 10. Removing the WB250 measuring head and sensor panel assemblies (front view).

- b. Use a 1/2-inch open-end wrench, or a 1/4-inch Allen wrench (as required), to *loosen* the two capscrews below the inboard end of the measuring head. These are located inside the cutout at the rear of the balancer. The capscrews fit into keyhole slots on the balancer base. Loosen them a few turns; do not remove them.
 5. Slide the measuring head and sensor panel assembly outboard (toward the spindle) to free the screws from the keyhole slots. Then lift the assembly off the balancer base.
- CAUTION:** Do not scratch the sensor timing disc or get it dirty. Doing so can cause the balancer to malfunction.
6. Use a 3/8-inch wrench to remove the 9 elastic stopnuts (ESNA) from the studs that secure the sensor panel assembly to the measuring head. Then remove the sensor panel assembly.
 7. If the measuring head is to be replaced, hold the spindle flange securely and use a 9/16-inch wrench to remove the stub shaft bolt and stub shaft from the spindle. Install the stub shaft on the new measuring head.
 8. When reassembling the measuring head and sensor panel assembly, observe the following precautions:
 - a. Move the brake solenoid plunger so it clears the brake.
 - b. Make sure that the sensor timing disc is centered in the sensor slot.
 9. Reinstall the assembly on the balancer base.
 10. Reinstall the control housing and weight tray, and reconnect ac power.

Brake Adjustment

The automatic brake is adjusted and calibrated at the factory and normally does not need readjustment. In general, the brake is adjusted so that a 14" wheel stops in 1-1/2 to 2 turns, and a 15" wheel stops in two turns. If brake application seems incorrect, either too slow or too fast, adjust the brake as follows, figure 11:

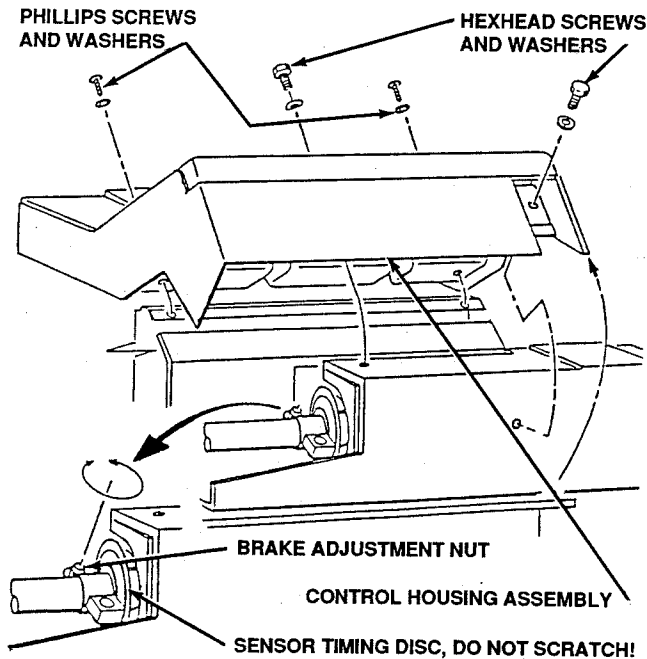

Figure 11. Adjusting the brake.

1. Disconnect ac power from the balancer.
2. On WB260A models, remove the left hand weight tray as previously described.
3. Remove all weights and other material from the control housing.
4. Use a 1/2-inch socket to remove the two hexhead screws and washers from the weight tray. *Do not* remove the weight tray and control housing assembly. It is connected to PC board cables.
5. On WB260A models, remove two Phillips screws and washers from the weight pockets.
6. Carefully tilt the weight tray and control housing assembly backwards until the brake band is exposed.
7. Support the weight tray and control housing assembly during brake adjustment. Do not let it balance unsupported on the rear of the balancer frame.
8. Locate the brake band clamping bolt with the rubber spacer and use a 1/2-inch wrench to tighten or loosen the nut as required for the desired brake application. Usually one-quarter turn of the clamp nut is enough for proper adjustment.
9. Reposition the control housing assembly on the balancer and reinstall the mounting screws.
10. Reinstall the weight tray and reconnect ac power.

CAUTION: Do not scratch the sensor timing disc or get it dirty. Doing so can cause the balancer to malfunction.

NOTE: One of the two clamping bolt assemblies on the brake band has a steel spacer washer in the brake band opening. The other has a rubber spacer bushing in the brake band opening

SPECIFICATIONS

- Dynamic and static balance, twin-plane balance in six modes: normal, static, and four Custom modes.
- Single spin cycle: approximately 7 seconds.
- Weight displayed in grams or ounces.
- Weight displayed in 0.25-ounce (5-gram) increments for standard balancing in all modes.
- Fine balancing to 0.10 ounce (2 grams) in all modes.
- Automatic weight recalculation with changes in dimensions or mode selection.
- Automatic calibration program.
- Maximum tire and wheel weight — 154 pounds (70 kilograms)
- Operation from 110/120 volts, 50/60 Hz., or 12 vdc. (Other options are available.)
- **Passenger Car and Light Truck Wheel and Tire Specifications:**
 - Diameter — 10 to 17 inches
 - Width — 3.5 to 14 inches
 - Offset (distance) — 3.2 to 9 inches
- **Motorcycle Wheel and Tire Specifications:**
 - Diameter — 10 to 24 inches (Requires motorcycle adapter kit)

WB250 and WB260A PARTS LIST
(See Assembly Drawing On Next Page)

Item	Part Number	Description	Qty.
1	WB7553-02	Control Housing	1
2	WB0205-0031	Washer, 5/16" x 7/8"	4 (2 on WB250)
3	WB0102-3118-12	Hexhead Capscrew, 5/16-18 x 3/4"	8 (6 on WB250)
3a *	WB0103-3118-12	Socket-head Capscrew, 5/16-18 x 3/4"	4 *
4	WB7667-01	Measuring Head Assembly	1
5	WB1179-02	Stub Shaft	1
6	WB0110-3824-81	Hexhead Bolt, 3/8-24 x 6"	1
7	WB0205-0032	Washer, 5/16" x 1/2"	4
8	WB7767-02	Base w/Base Mat, WB250	1
	WB7803-03	Base w/Base Mat, WB260A	1
9	WB2653-01	Base Mat, WB250	1
	WB2653-02	Base Mat, WB260A	1
10	KN300R	Snap-On Logo Nameplate	1
11	WB3700-0009	Tinnerman Clip, WB260A	4
12	WB7673	Sensor Panel Assembly	1
13	WB0201-0010	Flatwasher, No. 10	9
14	WB0302-1032	Hexnut, ESNA 10-32	9
15	WB7708	Back Cover, WB260A	1
	WB2677	Back Cover, WB250	1
16	WB0901-0818-08	Screw, 8-18 x 1/2"	7
17	WB5056-0007-02	PC Board Assembly	1
18	WB8073	Switch Extender	3
19	WB7699-02	Front Panel Decal	1
20	WB1591-02	Control Knob	3
21	WB8041-02	Display Window	1
22	WB7602	Weight Tray, Left-hand, WB260A	1
23	WB0907-1214-10	Screw, 12-14 x 5/8", WB260A	4
NS	WB1595-01	Weight Tray Label Set, Ounces	1
NS	WB1595-02	Weight Tray Label Set, Grams	1 (optional)
NS	WB2543	Caliper Hook	1
NS	WB6605-01	AC/DC Power Converter	1

* Alternate mounting fastener for measuring head assembly

For service or parts assistance, call: 1-(800) 332-2526

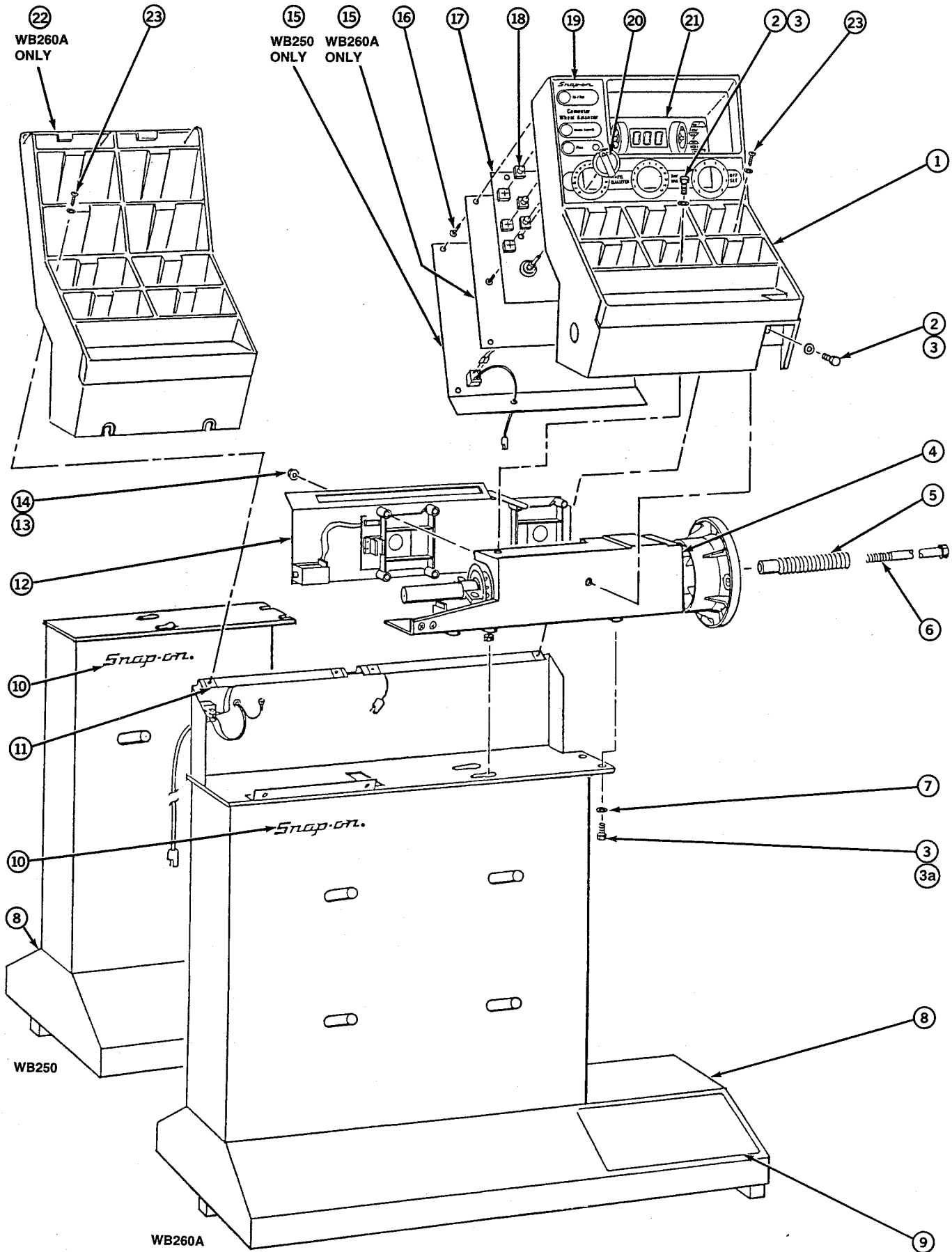

The WB250 and WB260A precision wheel balancers (exploded view).

Mounting With The Metric Bolt Plate Adapter

The metric bolt plate adapter can be used in place of the universal wheel adapter to mount wheels with untrue centers or closed centers. Install and mount the adapter as follows:

1. Select the lug pattern: 3, 4, or 5 holes. Measure the wheel bolt pattern to determine the number of bolts and pitch circle for the wheel.
2. Insert the studs into the bolt plate as required for the number of bolts and pitch circle of the wheel. Both 10-mm and 12-mm studs are provided. Use the 12-mm studs whenever possible. Tighten the studs securely by hand.

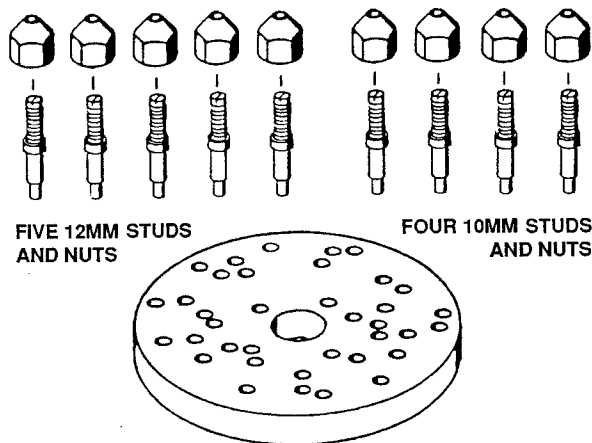

NOTE: This step can be done with the adapter on or off the balancer.

3. Check the cleanliness of the balancer mounting flange and the rear surface of the adapter before mounting the adapter on the balancer. If the adapter does not seat squarely and securely against the flange, inaccurate readings will result.
4. Install the adapter on the balancer with the two hexhead Allen screws provided. Use a 5/16-inch (8-mm) wrench to tighten the screws securely. If the adapter is not mounted securely, inaccurate readings will result.
5. Mount the wheel on the adapter and install the wheel nuts hand tight. Torque the nuts to 100 inch-pounds in an alternating pattern. *Do not use an impact wrench.*
6. Proceed with balancing.

Mounting The Motorcycle Adapter Kit

Install the motorcycle adapter kit on your Snap-on balancer and mount motorcycle wheels as follows:

1. Hold the balancer shaft from rotating.

2. Using a 9/16-inch wrench, remove the bolt from the end of the balancer shaft and remove the shaft.
3. Install the motorcycle spindle (1) and torque to 50 to 70 inch-pounds.

CAUTION: The motorcycle spindle is made of specially selected steel for strength and long life. Because of the small spindle diameter, however, you should be especially careful not to bend the spindle.

4. Mount a motorcycle wheel on the adapter spindle as follows:

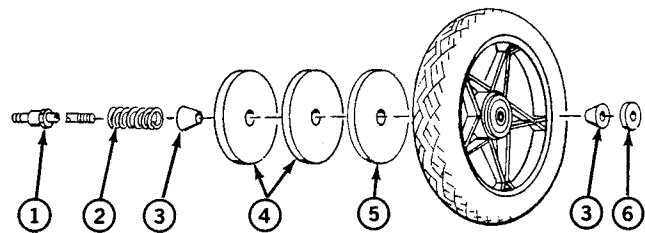

Item	Part No.	Description	Qty.
1	WBM1400	Motorcycle spindle	1
2	WBM1401	Compression spring	1
3	WBM1387	Cone	2
4	WBM1389-01	Pressure disc	2
5	WBM1389-02	Pressure disc (laminated)	1
6	WBM1388	Ring nut	1

- a. Slide the cone spring (2) and cone (3) onto the spindle (1).
- b. Select two or three pressure discs (4 and 5) and slide them over the spindle, cone, and compression spring until flush with the balancer mounting flange.

NOTE: The number of discs (4) used will depend on the design and shape of the wheel. Always place the laminated side of the disc (5) toward the wheel.

- c. Place the wheel on the spindle with the brake drum or disc facing the pressure disc (5).
- d. Slide the second cone (3) onto the spindle.
- e. Be sure that the wheel is centered on both cones and tighten the ring nut (6).

NOTE: Tighten the ring nut by hand only enough to hold the wheel securely and prevent it from slipping when the balancer brake is applied. Overtightening can cause excessive wear on the pressure disc.

5. Proceed with balancing.

NOTE: When reinstalling the standard stub shaft on the balancer spindle, torque the mounting bolt to 250 to 300 inch-pounds.

APPENDIX — SPECIAL MOUNTING ADAPTERS

Several special mounting adapters are available as optional accessories for your Snap-on balancer. These include:

- The universal wheel adapter (part no. WBA2)
- The metric bolt plate adapter (part no. WB1499)
- The motorcycle wheel adapter (part no. WBM1419)

The following sections explain the installation and use of these adapters.

Mounting With The Universal Wheel Adapter

The universal wheel adapter is used on wheels with untrue center holes, closed centers, or other designs where cone mounting is not possible. The universal adapter fits 3-, 4-, 5-, 6-, 8-, and 10-hole patterns. Install and mount the adapter as follows:

1. Select the lug pattern: 3, 4, or 5 holes. (For 6 lugs, select 3; for 8 lugs, select 4; for 10 lugs, select 5.) Follow the stamped numbers on the back of the adapter plate for the selected pattern.

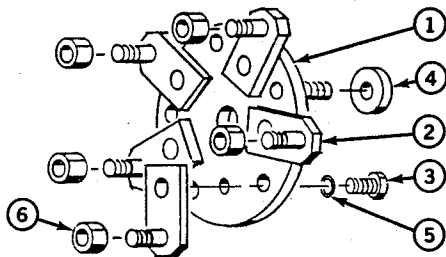

Item	Part No.	Description	Qty.
1	WBA2-1	Adapter plate	1
2	WBA2-2	Swivel plate	5
3	WBA2-3	Swivel screw	5
4	WBA2-4	Flange nut	2
5	WBA2-5	O-ring	5
6	WBA2-6	Wheel nut, 14-mm (optional)	5
6	WBA2-6A	Wheel nut, 60° (standard)	5

2. Install the swivel plates (2) to the adapter plate (1).
3. Insert the swivel screws (3) with O-rings (5) and tighten snugly. Then loosen just enough so that the swivel plates can be rotated.
4. Tilt the wheel to 45 degrees leaning against the balancer or a bench. Move all swivel plates in the same direction and to the approximate diameter of the hole pattern.

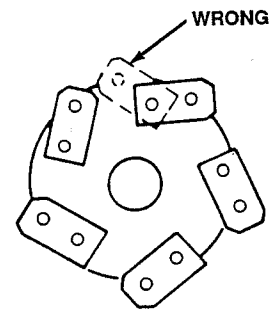

Insert the swivel plate studs into the mounting holes from the rear of the wheel. Insert the lower studs first; then align and tilt the top studs into place.

5. Hold the wheel and adapter together and tilt the wheel vertically. Install the wheel nuts (6) and tighten by hand. Torque the nuts to 75 inch-pounds in an alternating pattern. *Do not use an impact wrench.*

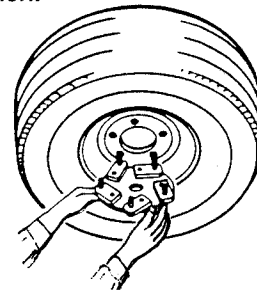

NOTE: The WBA2-6A wheel nut has a 90° tapered end and a 60° tapered end. Use the 90° end on most wheels. Use the 60° end on wheels with 60° countersunk holes, such as Honda wheels. A 14-mm spherical nut (WBA2-6) is available for older VW wheels.

6. Torque the swivel screws on the adapter rear to 75 inch-pounds. *Do not use an impact wrench.*
7. Mount the wheel and the adapter on the balancer. Be sure the rear surface of the balancer is free of dirt and nicks before mounting. If the adapter does not seat squarely against the balancer flange, inaccurate readings will result.
8. Install and tighten the two flange nuts (4) that hold the adapter to the mounting flange. Be sure that the flange nuts are completely tight, or inaccurate readings will result. Doublecheck the flange nut tightness after the first spin.
9. Proceed with balancing

Other wheels of identical size can be mounted directly to the adapter without removing it from the balancer. When mounting a wheel to the adapter, tighten the wheel nuts by hand and then torque gradually to 75 inch-pounds in an alternating pattern. Rotate the wheel several times while tightening the nuts to ensure that the wheel is centered.

STUB SHAFT INSTALLATION

From the right side of the balancer, install the stub shaft and bolt into the spindle. Using a torque wrench, tighten the bolt to 250-300 inch-pounds.

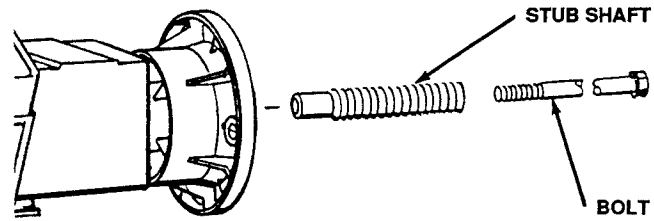

Snap-on®

Form ZWB260A

©SNAP-ON TOOLS CORPORATION KENOSHA, WI 53141-1410

Printed in U.S.A. 11/93

"FOR REFERENCE ONLY"